

## Patent Law

- Module A

## The elements of Patentability

- **Patentable subject matter**, i.e., patent eligibility
- **Useful/utility** (operable and provides a tangible benefit)
- **New** (novelty, anticipation)
- **Nonobvious** (not readily within the ordinary skills of a competent artisan at the time the invention was made)
- **Specification requirements / disclosure requirements** (enablement, written description, best mode, definiteness)

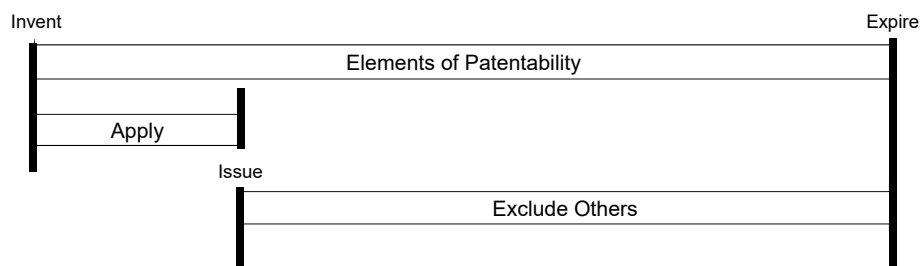

## Infringement

- 35 U.S.C. §271

- (a) Except as otherwise provided in this title, whoever without authority makes, uses, offers to sell, or sells any patented invention, within the United States or imports into the United States any patented invention during the term of the patent therefor, infringes the patent.



## Hall '626 patent items

Claim 1 element/limitation	Label	Snippets from the claim
box upper member	A	
box lower member	B	"comprising three laminated layers"
lower member first layer (bottom/outside)	C	"flat on its interior side"
lower member second layer (middle; barrier layer means)	D	"resistant to at least moisture and being spread across the said first flat interior surface" "said first and second flat surfaces being bonded together in a face to face relationship with said barrier layer means interposed therebetween"
lower member third layer (inside; flutes on its upper side)	E	
flutes	F	"plurality of spaced parallel flutes"
ridges	G	"flutes comprising a plurality of upwardly directed ridges defining therebetween upwardly directed open channels, said ridges forming means for supporting an article above the bottoms of said channels"
venting means	H	"located in a side wall of said box at the ends of said channels, the dimensions of said box being such that heat from an article resting on said flutes escapes through said ventilation means via said channels"

Claim 1: A box comprising upper and lower members which close or open relative to each other to form a covered box, a bottom of said box being formed by said lower member and comprising three laminated layers, a first and outside one of said three laminated layers forming a supporting layer having a first and substantially flat surface on its interior side, a second and intermediate one of said three laminated layers extending over at least a substantial portion of said first flat interior surface, said second layer comprising barrier layer means resistant to at least moisture and being spread across the said first flat interior surface, a third and inside one of said three layers having a second and substantially flat surface on its lower side with a plurality of spaced parallel flutes upstanding on its upper side, said first and second flat surfaces being bonded together in a face to face relationship with said barrier layer means interposed therebetween, said flutes comprising a plurality of upwardly directed ridges defining therebetween upwardly directed open channels, said ridges forming means for supporting an article above the bottoms of said channels, and venting means formed in said box and located in a side wall of said box at the ends of said channels, the dimensions of said box being such that heat from an article resting on said flutes escapes through said ventilation means via said channels.

## Hall '626 patent items

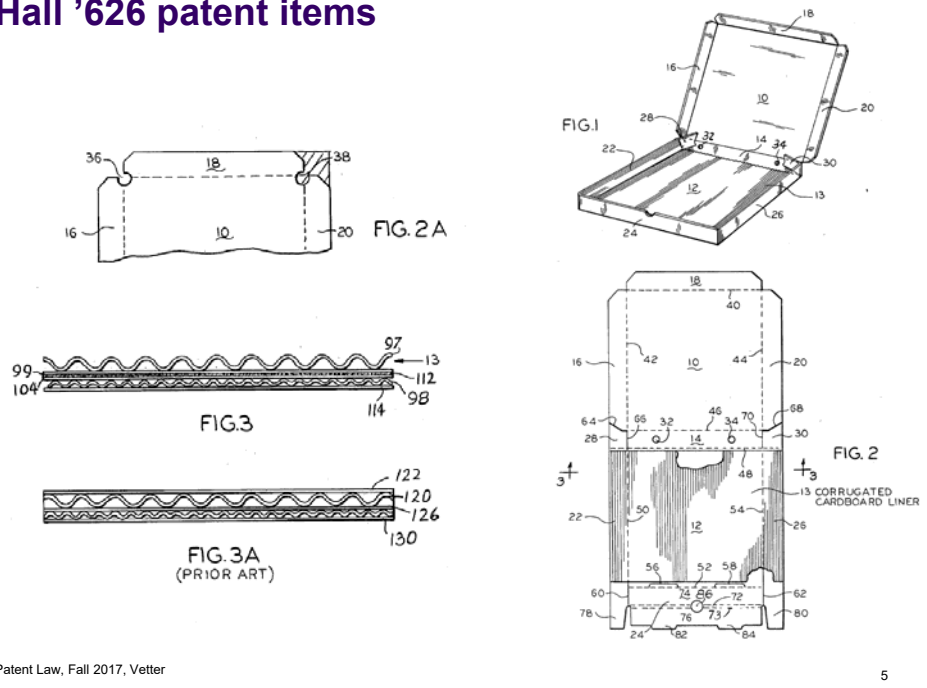

## 35 USC §101

Whoever invents or discovers any  
new and useful  
process,



machine, manufacture, or  
composition of matter,

or any new and useful improvement  
thereof,

may obtain a patent therefor, subject to the  
conditions and requirements of this title

“Product”  
claims or  
inventions

## Basis for Patent Rights

Option	Problem	→			Benefit	Cost
 No IP	Public good nature of info: -nonrivalrous -nonexcludable	Invest in R&D, create & sell product	Imitations sell at lower cost	May not be able to recover R&D costs	Getting info is "cost free"	Info under produced
 IP	Costs associated with limiting access to info	Invest in R&D, create & sell product	IP rights block imitators to some degree	Recoup R&D with (hopefully) a profit	Info is produced & supplied*	Limits to access of info, ↑ transaction costs

## Commentary on Authors & Inventors clause

<p>It was beneficial to all parties, that the national government should possess this power; <u>to authors and inventors</u>, because, otherwise, they would have been subjected to the <b><i>varying laws and systems of the different states on this subject, which would impair, and might even destroy the value of their rights</i></b>; <u>to the public</u>, as it would promote the <b><i>progress of science and the useful arts</i></b>, and admit the people at large, after a short interval, to the full possession and <b><i>enjoyment of all writings and inventions without restraint</i></b>.</p>	<p>Federalism concerns place much of IP law at the Federal level</p> <p>IP laws exist as a public policy tool to promote production of inventions and works for the public domain (eventually)</p>
<p>In short, the only boon, which could be offered to inventors to disclose the <b><i>secrets</i></b> of their discoveries, would be the <b><i>exclusive right</i></b> and profit of them, as a monopoly for a limited period.</p>	<p>Patent versus Trade Secret protection</p>
<p>And authors would have little <b><i>inducement to prepare elaborate works</i></b> for the public, if their publication was to be at a large expense, and, as soon as they were published, there would be an unlimited right of <b><i>depredation and piracy</i></b> of their copyright.</p>	<p>Copyright to support production and distribution of works</p>

## Claims

- Claims are the heart of the patent system
- **Inventors** are those who thought of something covered by the claims, not those who learned it from someone else
  - You may not know who they are until claims are drafted
- Claims define the scope of coverage of the right to exclude
- Those who **operate within the language of the claim** are subject to an infringement action

## Patent – claims



1. A **seating apparatus, comprising:**
  - (a) a horizontal **seat**, and
  - (b) three **legs** each having one end connected to the **bottom** of said horizontal **seat**.

1. A device for supporting objects, **comprising:**
  - (a) a horizontal support member; and
  - (b) three vertical support members each having one end connected to the same face of said horizontal support member.

## Claim Example

- Client shows you a machine she has devised. It has:
  - Chassis
  - 4 wheels
  - 10-cylinder engine
  - Brake on each wheel
  - 3-speed transmission
- How to Claim?
  - Rule 1 - as broad as possible but must not cover any previously known configuration.
  - Rule 2 - Claim must embrace something the inventor devised
- Assume that the closest previously known machine is the horse-drawn wagon
- Claim 1:
  - A vehicle, comprising:
    - a chassis;
    - a plurality of wheels attached to said chassis; and
    - an engine for turning one of said wheels.
- Goals
  - Don't give up broadest claim scope
  - Write many other, narrower, claims in case Claim 1 is found to violate Rule 1.



## Claim Example (cont'd)

- New information on prior art
  - You learn at some point that the locomotive pre-existed your client's development of the car
- This generates a need to amend the claim
- (amended) Claim 1:
  - A vehicle, comprising:
    - a chassis;
    - a plurality of wheels attached to said chassis;
    - an engine for turning one of said wheels;
    - A steering device for turning at least one of said wheels.

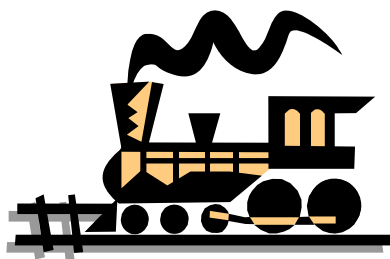

## Claim elements/limitations

- In claims using the transition word “comprising,” adding more elements/limitations makes the claim more narrow (i.e., there are a smaller number of items that might be covered by the claim)
  - There are other ways to make the claim more narrow, this is not the only way
- For example, arrange these three claims from most to least broad:

### Claim 1

- A device for supporting objects, comprising:
  - (a) a horizontal support member; and
  - (b) three vertical support members each having one end connected to the same face of said horizontal support member.

### Claim 3

- A **seating apparatus**, comprising:
  - (a) a horizontal **seat**;
  - (b) three **legs** each having one end connected to the **bottom** of said horizontal **seat**;and
  - (c) said connection between said legs and bottom of said horizontal seat being a slim metal piece partially traversing some of said leg and said seat.

### Claim 2

- A **seating apparatus**, comprising:
  - (a) a horizontal **seat**; and
  - (b) three **legs** each having one end connected to the **bottom** of said horizontal **seat**.

## Dependent claims

1. A seating apparatus, comprising:
  - (a) a horizontal seat; and
  - (b) three legs each having one end connected to the bottom of said horizontal seat.

### Examples of dependent claims:

2. *The seating apparatus of **claim 1** further including rubber caps at the end of each said leg opposite the end of said leg connected to the bottom of said horizontal seat.*
3. *The seating apparatus of **claim 1** wherein the said horizontal seat is made from wood.*
4. *The seating apparatus of **claim 3** wherein the wood is one of the following types: oak, mahogany or ash.*

General rule of “claims scope”: the independent claim is always “broader” than its dependent claims.

“comprising” is a magic word. It makes the claim “open-ended” - any device or method that includes all the limitations after the word comprising will infringe, e.g. a four-legged stool infringes claim 1.

### More on claims – visualizing dependent claims

- Dependent claims are often visualized in a tree hierarchy

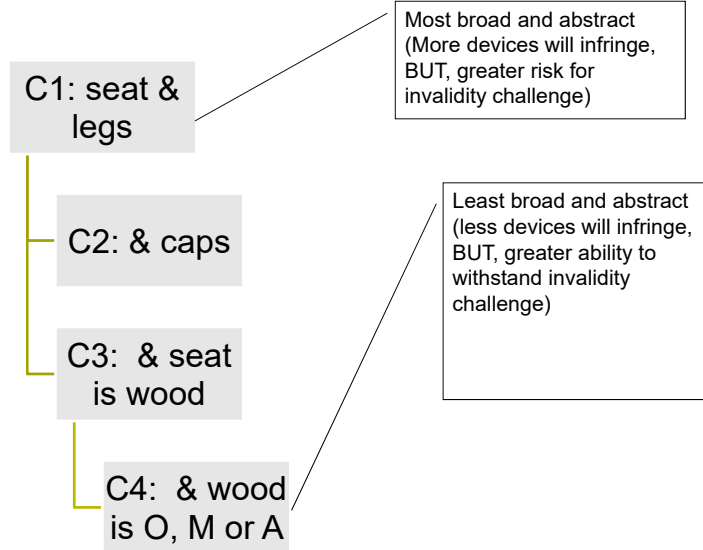

### More on claims – labeling elements/limitations

- Patent attorneys use a shorthand for discussing claim elements/limitations
- That short hand is to use a symbol, often letters, for each major component or subdivision, or major qualifier in the claim language

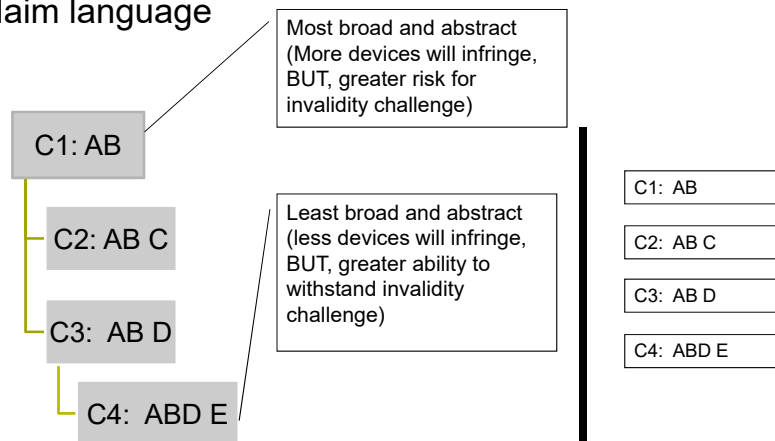



## Patent Document Terminology

### Sections of a patent document

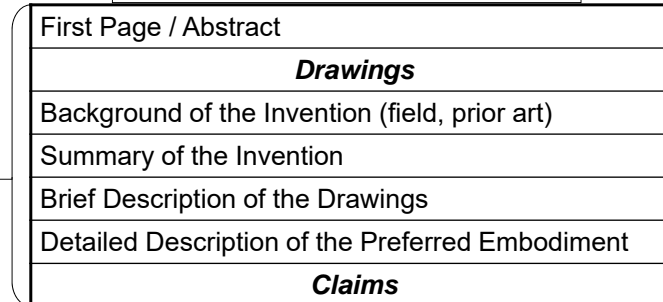

The “specification” is the entire disclosure

The “written description” is the textual description

The label “written description” that is used to describe a portion of the patent document is different from the **§112(a)** “written description requirement”

## Means plus function - § 112, ¶ 6

Revised hypothetical claim to demonstrate “means plus function” claim limitations

1. A modular wall section, comprising:		preamble
	<i>an edge-wise rectangular outer metal shell where the longer side of the rectangle is within the length range of 2 feet to 5 feet;</i>	A
	<i>one or more seals on one or both of the shorter sides of the rectangle for interfacing with other modular wall sections; and</i>	B
	<i> baffling means.</i>	C

