

Patent Law

- Module C

35 USC §101

Whoever invents or discovers any
new and useful
process,

machine, manufacture, or
composition of matter,

or any new and useful improvement
thereof,

may obtain a patent therefor, subject to the
conditions and requirements of this title

“Product”
claims or
inventions

Patent Eligibility - Process

- 35 U.S.C. 100(b)
 - The term "process" means process, art or method, and includes a new use of a known process, machine, manufacture, composition of matter, or material.
- Modern test of the bounds of the broad term "process" has been in relation to computer software
 - Is software more like abstract principles and mental steps or like implemented electronic circuits?

The Domain of Patent protection . . .

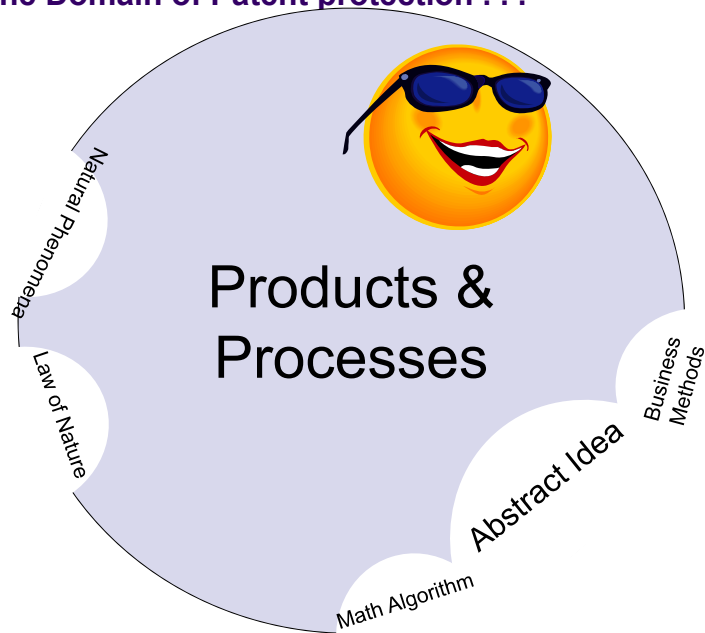

Diamond v. Chakrabarty, 447 U.S. 303 (1980)

- Patent application for genetically engineered bacteria
 - It had the property of breaking down multiple components of crude oil
 - Its intended application was to treat oil spills (never field tested or applied)
- Claim to the bacteria itself:
 - "a bacterium from the genus *Pseudomonas* containing therein at least two stable energy-generating plasmids, each of said plasmids providing a separate hydrocarbon degradative pathway."
- Various other claims in other claim formats
- Issue – is the bacteria a “manufacture” or “composition of matter” within the meaning of those terms as they apply from 35 U.S.C. §101?

Diamond v. Chakrabarty, 447 U.S. 303 (1980)

- Mode of analysis (in essence common to all of the patent eligibility cases)
 - First, determine whether the claim is “within” the meaning of one of the four statutory terms
 - Apply statutory interpretation “argument categories”
 - Meaning of the words (statutory definitions, plain meaning, canons of construction, past court opinions on the meaning)
 - Inferences from the provisions or structural characteristics of the statute or other related statutes (same word used in other places in the statute, significance of sectioning, divisions, cross-references, etc.)
 - Legislative History (a number of principles and “canons” are sometimes used to structure use of legislative history; for example, the sometimes employed doctrine that the legislative history should only be authoritative if the statutory language is ambiguous)
 - Policy and/or historical arguments
 - Second, even if the analysis from the first step seems to indicate that the claim is within one of the terms, evaluate whether the claim fits into one of the various remaining exceptions to patent eligibility
 - These exceptions are judicially created, so the mode of analysis looks more like the common law than like statutory interpretation (for example, the line of cases dealing with the now mostly defunct “mathematical algorithm” exception)

Diamond v. Chakrabarty, 447 U.S. 303 (1980)

- PTO rejection
 - Examiner rejected bacterial claims on two grounds
 - micro-organisms are “products of nature”
 - that as **living things micro-organisms are not patentable subject matter under § 101**.
 - A new “proposed” exception, or does it fit within one of the three exceptions? (natural phenomenon? but, human-made)
- Meanings of terms
 - Manufacture
 - produce articles for use from raw or prepared materials by giving these materials new forms, qualities, properties, or combinations
 - Composition of matter
 - all compositions of two or more, all composite articles – whether chemical or mechanical union/mixture, whether gases, fluids, powers or solids
 - Both “wide scope” terms

Diamond v. Chakrabarty, 447 U.S. 303 (1980)

- Legislative History
 - Language of 101 tracks closely with Jefferson’s originally-authored 1793 patent act
 - Embodies Jefferson’s philosophy that “ingenuity should receive a liberal encouragement”
 - Congress intended patentable subject matter to include “anything under the sun that is made by [humans]”
- Exceptions - Physical phenomena?
 - Compare to Funk (US 1948):
 - Applicant discovered certain bacteria whose characteristics were such that when mixed together they assisted the process of nitrogen fixation in plant roots
 - In rejecting the application the court said that the “use in combination does not improve in any way their natural functioning”
 - “they perform in their natural way”
 - Chakrabarty’s bacteria has “markedly different characteristics” from those in nature
 - Chakrabarty **transformed** the natural bacteria into his own handiwork
- Other considerations
 - Consider the definition of “invention” in §100, which says that “invention” means both “invention and discovery”

Diamond v. Chakrabarty, 447 U.S. 303 (1980)

- First counter argument
 - 1930 Plant Patent Act (seedless “asexual” reproduction)
 - 1970 PVPA (sexual reproduction, excluded bacteria)
 - Passage of both acts evidences congressional understanding that “manufacture” or “composition of matter” do not include living things – if they did, neither act necessary
 - Only one specific PPA legislative history provision stating that “the patent laws . . . at the present time are understood to cover only . . . inanimate nature”
- Not persuasive because there were other reasons to pass both acts
 - PPA – work of the breeder “in aid of nature” was patentable
 - Prior to 1930, even artificially bred plants considered “products of nature” (an instance of “natural phenomena”)
 - Written description problem for plant patent (may differ only by color or perfume) (relaxed by PPA)
 - **Relevant distinction is not between living and inanimate things, but between products of nature, whether living or not, and human-made inventions**
 - PVPA – sexually reproduced plants not included in PPA because new varieties could not be reproduced true-to-type through seedlings in 1930
 - PVPA excluded bacteria (i) simply in agreement with a court case that held that bacteria were not plants under PPA, or (ii) because prior to 1970 the PTO had granted some patents on bacteria

Diamond v. Chakrabarty, 447 U.S. 303 (1980)

- Second counter argument – need Congress to authorize patents on micro-organisms, genetic technology unforeseen when §101 enacted
 - Flook: the judiciary “must proceed cautiously when . . . asked to extend patent rights into areas wholly unforeseen by Congress”
 - Congress has spoken, court says it is simply doing its Marbury duty to say what the law is – high policy choice is not for the court and has already been made by congress
 - Congress is free to amend to exclude these inventions, and has similarly done so for nuclear weapons technology

Two other recent Supreme Court cases

- “process claims”

- *Mayo Collaborative Servs. v. Prometheus Labs., Inc.*, 132 S. Ct. 1289 (2012)
 - claimed method recited a process of (1) administering the drug, (2) detecting the level of metabolites, and based on discovered correlations, (3) increasing or decreasing the amount of the drug additionally administered

- “product” claims

- *Association for Molecular Pathology v. U.S. Patent and Trademark Office*, 689 F.3d 1303 (Fed. Cir. 2012) (en banc) (finding certain types of isolated DNA sequences eligible).
- Cert granted on this question: “Are human genes patentable?”
- From Petitioner-Appellant brief:
 - The broad preemptive effect of these patents is further evidence that they claim laws and products of nature. The patents cover all isolated forms of the naturally occurring genes, whether previously identified or not. The patents grant Myriad the authority to prevent all research and clinical testing of the genes, raising the same concerns about patenting a “building-block” that has troubled the Court.

Mayo v. Prometheus, (Sup. Ct. 2012)

- Concerns
 - Don't reward “draftsman's art” for writing clever claims to a natural law
 - Processes that too broadly preempt use of the natural law
 - Need elements (“inventive concept”) sufficient to ensure that the claim is more than to the natural law itself
- The claim at issue, apart from the natural law, is conventional; the steps used are routine, well-understood
- Fed Cir reversed Dist Ct., applying Machine or Transformation (MorT) test to find no eligibility problem, then post-*Bilski*, stayed the course with MorT as a “clue”

A method of optimizing therapeutic efficacy for treatment of an immune-mediated gastrointestinal disorder, comprising:

(a) **administering** a drug providing 6-thioguanine to a subject having said immune-mediated gastrointestinal disorder; and

(b) **determining** the level of 6-thioguanine in said subject having said immune-mediated gastrointestinal disorder,

“wherein the level of 6-thioguanine less than about 230 pmol per 8×10^8 red blood cells indicates a need to increase the amount of said drug subsequently administered to said subject and “wherein the level of 6-thioguanine greater than about 400 pmol per 8×10^8 red blood cells indicates a need to decrease the amount of said drug subsequently administered to said subject.”

Essential Problem for Patent Eligibility

Where does a patent eligible “process” stop and where does a “law of nature” (such as a mathematical algorithm) begin? Benson, Diehr, Flook

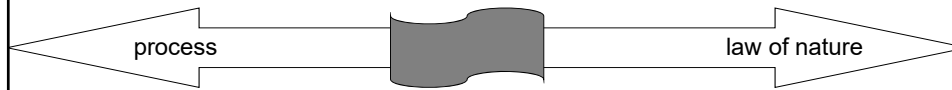

Where does a patent eligible product (machine, manufacture, composition of matter) stop and where does a “natural phenomena” begin? Chakrabarty



Parker v. Flook (US 1978)

- Claim is to method for updating alarm limits
- PTO rejected, CCPA reversed, Supreme Court reversed – rejecting the claim as not patent eligible
- Court considered the application to be of an abstract nature and wholly focused upon the calculation of the alarm limit
 - It did not save the claim that it was limited to the specific process of catalytic conversion and had “post-solution” activity to adjust the alarm limit
- Dissent accused majority of applying novelty and nonobviousness criteria in place of patent eligibility

Diamond v. Diehr

- Claimed method for operating a rubber molding press with a digital computer such that articles are in the press for the proper amount of time
- Examiner rejected claims as nonstatutory subject matter under §101
- PTO Board affirmed, CCPA (Rich, J.) reversed, concluding that the claims were not directed to a mathematical algorithm, but to an improved process for molding rubber articles



Diamond v. Diehr	1. A method of operating a rubber-molding press for precision molded compounds with the aid of a digital computer, comprising:		
	"providing said computer with a data base for said press including at least,	A	
	"natural logarithm conversion data (ln),	A.1	
	"the activation energy constant (C) unique to each batch of said compound being molded, and	A.2	
	"a constant (x) dependent upon the geometry of the particular mold of the press,	A.3	
	"initiating an interval timer in said computer upon the closure of the press for monitoring the elapsed time of said closure,	B	
	"constantly determining the temperature (Z) of the mold at a location closely adjacent to the mold cavity in the press during molding,	C	
	"constantly providing the computer with the temperature (Z),	D	
	"repetitively calculating in the computer, at frequent intervals during each cure, the Arrhenius equation for reaction time during the cure, which is	E	
	"ln v = CZ + x	E.1	
	"where v is the total required cure time,	E.2	
	"repetitively comparing in the computer at said frequent intervals during the cure each said calculation of the total required cure time calculated with the Arrhenius equation and said elapsed time, and	F	
"opening the press automatically when a said comparison indicates equivalence.	G		

Diamond v. Diehr

- Is this claimed process patentable subject matter?
- Background statutory arguments
 - Give statute's words plain, broad meaning
 - Legislative history: "anything under the sun that is made by [humans]"
 - History: this type of industrial process is historically patentable subject matter
- How to analyze a claim for §101 analysis
 - consider claim as a whole – inappropriate to dissect for purposes of §101 patent eligibility analysis
 - New process may be patentable even if all steps known and in common use before the combination is made
 - Word "new" in "new and useful" does not mean that the novelty analysis is a part of §101 and patent eligibility



Diamond v. Diehr

- Holding(s)
 - a mathematical formula as such is not protectable, Benson
 - this principle cannot be circumvented by attempting to limit the use of the formula to a particular technological environment, Flook
 - when a claim containing a mathematical formula implements or applies that formula in a structure or process which, when considered as a whole, is performing a function which the patent laws were designed to protect (e. g., transforming or reducing an article to a different state or thing – making it **markedly different**), then the claim satisfies the requirements of § 101

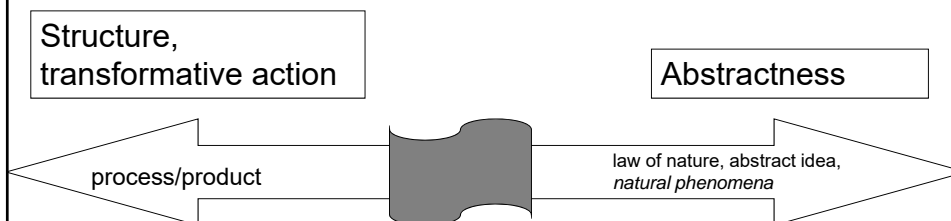

Assn. of Molecular Pathology v. Myriad Genetics, __ U.S. __ (2013)

'252 claim 1: An isolated DNA coding for a BRCA1 polypeptide, said polypeptide having the amino acid sequence set forth in SEQ ID NO:2.

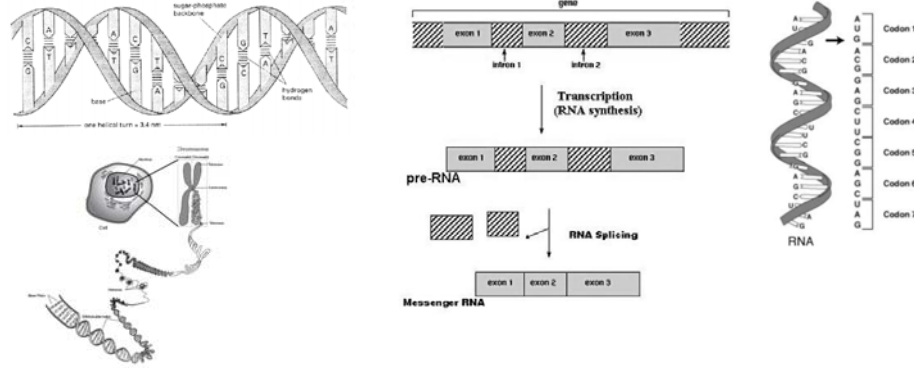

- Isolated DNA sequence
- cDNA sequence

cDNA does not present the same obstacles to patentability as naturally occurring, isolated DNA segments. As already explained, creation of a cDNA sequence from mRNA results in an exons-only molecule that is not naturally occurring.

“Step Change” in Patent Law - Abstract Ideas & Business Methods

- Eligible Subject Matter
 - Bus. Methods
 - Bus. Methods!
 - Bus. Methods??
 - Non-abstract processes
- Utility
- Statutory Bars, Novelty
- Non-obvious
- Disclosure Requirements

Increasingly abstract software claims but no adjustment of disclosure requirements

In re Bilski (Fed. Cir. 2008) (en banc)

- Claimed method does not transform an “article”
 - Machine-or-Transformation (MoT) is **THE** test
 - Need meaningful limits on claim scope
 - Field preemption prevention policy concern (vs. particular application)
- “articles”
 - “The raw materials of many information-age processes, however, are electronic signals and electronically-manipulated data.”
 - Make it a “different state or thing”
 - Too abstract to be an article: “legal obligations, organizational relationships, and business risks.”
 - Data that represents physical and tangible objects/substances is an “article”

Bilski claim 1: A method for managing the consumption risk costs of a commodity sold by a commodity provider at a fixed price comprising the steps of:

(a) initiating a series of transactions between said commodity provider and consumers of said commodity wherein said consumers purchase said commodity at a fixed rate based upon historical averages, said fixed rate corresponding to a risk position of said consumer;

(b) identifying market participants for said commodity having a counter-risk position to said consumers; and

(c) initiating a series of transactions between said commodity provider and said market participants at a second fixed rate such that said series of market participant transactions balances the risk position of said series of consumer transactions

Bilski v. Kappos, 130 S. Ct. 3218 (2010)

- Some methods of doing business might pass muster as a “process” under section 101
 - After State Street, Congress enacted a type of “prior user rights” for methods of doing business
 - This foreclosed an interpretation where one might say “no business methods can be a ‘process’ in a section 101 sense
- The “machine-or-transformation” test is not the only test for when a claim recites a qualifying “process”
- Emphasis is still on the need for limits on the claim to make it non-abstract
 - Field preemption prevention policy concern (vs. particular application)

Bilski claim 1: A method for managing the consumption risk costs of a commodity sold by a commodity provider at a fixed price comprising the steps of:

(a) initiating a series of transactions between said commodity provider and consumers of said commodity wherein said consumers purchase said commodity at a fixed rate based upon historical averages, said fixed rate corresponding to a risk position of said consumer;

(b) identifying market participants for said commodity having a counter-risk position to said consumers; and

(c) initiating a series of transactions between said commodity provider and said market participants at a second fixed rate such that said series of market participant transactions balances the risk position of said series of consumer transactions

Bilski v. Kappos, 130 S. Ct. 3218 (2010)

- Commentary on the machine or transformation test and on business methods as claimed processes:

n.8 This Court's precedents establish that the machine-or-transformation test is a useful and important clue, an investigative tool, for determining whether some claimed inventions are processes under § 101. The machine-or-transformation test is not the sole test for deciding whether an invention is a patent-eligible "process." . . .

the machine-or-transformation test would create uncertainty as to the patentability of software, advanced diagnostic medicine techniques, and inventions based on linear programming, data compression, and the manipulation of digital signals . . .

Interpreting § 101 to exclude all business methods simply because business method patents were rarely issued until modern times revives many of the previously discussed difficulties. . . . At the same time, some business method patents raise special problems in terms of vagueness and suspect validity. See *eBay Inc. v. MercExchange, L.L. C.*, 547 U.S. 388, 397 (2006) (KENNEDY, J., concurring). The Information Age empowers people with new capacities to perform statistical analyses and mathematical calculations with a speed and sophistication that enable the design of protocols for more efficient performance of a vast number of business tasks. If a high enough bar is not set when considering patent applications of this sort, patent examiners and courts could be flooded with claims that would put a chill on creative endeavor and dynamic change.

Bilski claim 1: A method for managing the consumption risk costs of a commodity sold by a commodity provider at a fixed price comprising the steps of:

- (a) initiating a series of transactions between said commodity provider and consumers of said commodity wherein said consumers purchase said commodity at a fixed rate based upon historical averages, said fixed rate corresponding to a risk position of said consumer;
- (b) identifying market participants for said commodity having a counter-risk position to said consumers; and
- (c) initiating a series of transactions between said commodity provider and said market participants at a second fixed rate such that said series of market participant transactions balances the risk position of said series of consumer transactions

Alice Corp. Pty. Ltd. v. CLS Bank Intl (2014)

- Preemption concern
- Two-Step "Test"

In *Mayo*, we set forth a framework for distinguishing patents that claim laws of nature, natural phenomena, and abstract ideas from those that claim patent-eligible applications of those concepts. First, we determine whether the claims at issue are directed to one of those patent-ineligible concepts. If so, we then ask, "[w]hat else is there in the claims before us?" To answer that question, we consider the elements of each claim both individually and "as an ordered combination" to determine whether the additional elements "transform the nature of the claim" into a patent-eligible application. We have described step two of this analysis as a search for an "inventive concept"—i.e., an element or combination of elements that is "sufficient to ensure that the patent in practice amounts to significantly more than a patent upon the [ineligible concept] itself."¹

¹[footnote] Because the approach we made explicit in *Mayo* considers all claim elements, both individually and in combination, it is consistent with the general rule that patent claims "must be considered as a whole." *Diamond v. Diehr*, 450 U.S. 175 (1981)..

claim 33: A method of exchanging obligations as between parties, each party holding a credit record and a debit record with an exchange institution, the credit records and debit records for exchange of predetermined obligations, the method comprising the steps of:

- (a) creating a shadow credit record and a shadow debit record for each stakeholder party to be held independently by a supervisory institution from the exchange institutions;
- (b) obtaining from each exchange institution a start-of-day balance for each shadow credit record and shadow debit record;
- (c) for every transaction resulting in an exchange obligation, the supervisory institution adjusting each respective party's shadow credit record or shadow debit record, allowing only those transactions that do not result in the value of the shadow debit record being less than the value of the shadow credit record at any time, each said adjustment taking place in chronological order, and
- (d) at the end-of-day, the supervisory institution instructing on[e] of the exchange institutions to exchange credits or debits to the credit record and debit record of the respective parties in accordance with the adjustments of the said permitted transactions, the credits and debits being irrevocable, time invariant obligations placed on the exchange institutions.

"the mere recitation of a generic computer cannot transform a patent-ineligible abstract idea into a patent-eligible invention"

PTO Eligibility Guidance

2014 Interim Eligibility Guidance Quick Reference Sheet

SUBJECT MATTER ELIGIBILITY TEST FOR PRODUCTS AND PROCESSES

PRIOR TO EVALUATING A CLAIM FOR PATENTABILITY, ESTABLISH THE BROADEST REASONABLE INTERPRETATION OF THE CLAIM. ANALYZE THE CLAIM AS A WHOLE WHEN EVALUATING FOR PATENTABILITY.

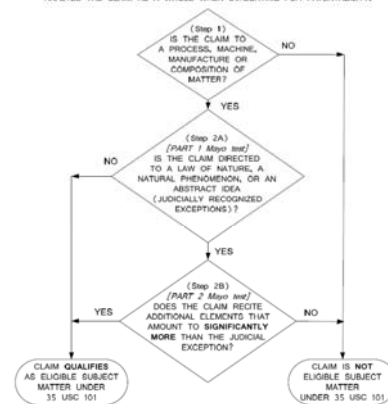

IN ACCORDANCE WITH COMPACT PROSECUTION, ALONG WITH DETERMINING ELIGIBILITY, ALL CLAIMS ARE TO BE FULLY EXAMINED UNDER EACH OF THE OTHER PATENTABILITY REQUIREMENTS: 35 USC §§ 102, 103, 112, and 101 (UTILITY, INVENTORSHIP, DOUBLE PATENTING) AND NON-STATUTORY DOUBLE PATENTING.

Notable changes from prior guidance:
• All claims (product and process) with a judicial exception (any type) are subject to the same steps.
• Claims including a nature-based product are analyzed in Step 2A to identify whether the claim is directed to (recites) a "product of nature" exception. This analysis compares the nature-based product in the claim to its naturally occurring counterpart to identify markedly different characteristics based on structure, function, and/or properties. The analysis proceeds to Step 2B only when the claim is directed to an exception (when no markedly different characteristics are shown).

US PTO 2014 Interim Guidance

- 2014 Interim Guidance on Patent Subject Matter Eligibility (Dec. 16, 2014)
 - Incorporates principles from legal precedent, in particular *Alice Corp.*, *Myriad* and *Mayo*
- Examples based on cases and hypotheticals
- Recently completed two-phase examiner training
 - <http://ptoweb.uspto.gov/patents/exTrain/101.html>

Subject Matter Eligibility Examination

US PTO Examiners are to:

1. Understand the claimed invention.
2. Determine if the claim falls into a statutory category.
3. Identify the judicial exception recited in the claim (if any).
4. Determine if the claim as a whole recites significantly more than the judicial exception itself.

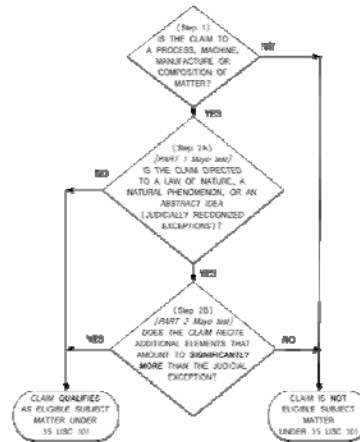

US PTO July 2015 Update

Responds to six major themes from public comments:

1. Additional Examples
2. Further Explanation of the Markedly Different Characteristics Analysis
3. Identifying Abstract Ideas
4. Making a *Prima Facie* Case and the Role of Evidence
5. Application of the 2014 Interim Guidance in the Examining Corps
6. The Role of Preemption and Streamlined Analysis

Additional examples from public submissions, case law, and issued patents:

Claimed Technology	Example Title
Business method	Transmission of Stock Quote Data
GUI	Graphical User Interface for Meal Planning
GUI	Graphical User Interface for Relocating Obscured Textual Information
Software	Method for Updating Alarm Limits
Software	Rubber Manufacturing
Mechanical	Internal Combustion Engine
Software	System Software - BIOS

Areas of Clarification:

- Additional art areas,
- Identifying abstract ideas
- Evaluation of "significantly more"
 - All elements together may provide significantly more even where individually conventional

Identifying Abstract Ideas – material from the US PTO

Courts' identification of abstract ideas reveals clusters of similar types:

<ul style="list-style-type: none"> ➤ Mitigating settlement risk ➤ Hedging ➤ Creating a contractual relationship 	<ul style="list-style-type: none"> ➤ Using advertising as an exchange or currency ➤ Processing information through a clearinghouse ➤ Managing a game of Bingo ➤ Mitigating settlement risk
<ul style="list-style-type: none"> ➤ Comparing a patient's gene with the wild-type gene, and identifying any differences that arise ➤ Comparing new and stored information and using rules to identify options ➤ Using categories to organize, store, and transmit information ➤ Organizing information through mathematical correlations 	<ul style="list-style-type: none"> ➤ The Arrhenius equation for calculating the cure time of rubber ➤ A formula for updating alarm limits ➤ A mathematical formula relating to standing wave phenomena ➤ A mathematical procedure for converting one form of numerical representation to another

Types of Utility

- operability
- beneficial/moral utility
- immediate benefit to the public, i.e., substantial utility, with its synonyms of practical and real-world utility
- specific utility, seeking to tie the utility to the claimed subject matter
- credible utility, so that the utility is provable to a POSITA.

From 2001 Revised Utility Guidelines: For example, a claim to a polynucleotide whose use is disclosed simply as a “gene probe” or “chromosome marker” would not be considered to be *specific* in the absence of a disclosure of a specific DNA target.

Juicy Whip, Inc. v. Orange Bang, Inc., 185 F.3d 1364 (Fed. Cir. 1999)

- Juicy Whip’s patent is for “post-mix” beverage dispenser that simulates the presentation of a “pre-mix” beverage dispenser
- District court, on S/J, held patent invalid
 - Purpose is to increase sales by deception
 - Other claimed usefulness (eliminating need to clean) is not independent of deceptive purpose and thus insufficient to raise a genuine issue of material fact
 - Improves prior art only by making the product more saleable
 - Is merely an imitation of a pre-mix dispenser

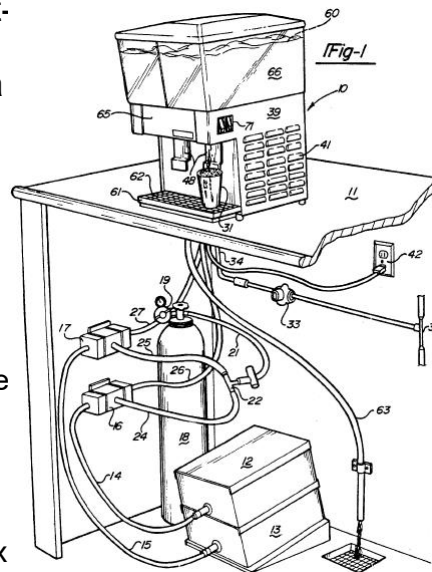

Juicy Whip v. Orange Bang



- Utility threshold is not high
 - merely need some identifiable benefit, useful result, or beneficial end
- District court applied two pre-1952 Second Circuit cases about creating artificial impressions of higher quality
 - “Spotting” unspotted tobacco leaves
 - “Seaming” seamless hosiery
- These cases do not represent the modern state of the utility doctrine
 - The fact that one product can be altered to make it look like another is in itself a specific benefit sufficient to satisfy the utility requirement
 - Product imitation is not unusual
 - It is not unlawful to display the simulated beverage
 - Utility requirement is not meant to make the courts or the PTO be arbiters of deceptive trade practices

In re Swartz (Fed. Cir. 2000)

The screenshot shows the homepage of the Cold Fusion Times website. The main heading is "COLD FUSION TIMES" with a subtitle: "The journal of the scientific aspects of finding isotopic fuels, new materials and the science and engineering of lattice-assisted nuclear reactions." Below this, there are navigation links for "CF Introductory Energy Production", "Current Issues", "Timeline", "References", "CF Energy Links", "CFI Energy, Inc.", "CFI/C710 Demo", and "CFI References". A section titled "UNCONSIDERED LANS/LENR/CF sites" lists various related websites. The main content area includes a link to "MIT IAP Course on Cold Fusion 1.01 - Brief Summary of Week 1" and "Cold Fusion Now's Jeremy 'Rex' videos of the lectures". There is also a section for "Updates" with a calendar interface showing dates from January 2016 to February 2016.

Brenner v. Manson

- Upon receiving Manson's application, the PTO rejects it for lack of utility
 - Claim is to a process that produces a composition of matter, specifically a steroid
- Manson requests an "interference" to prove he invented before Ringold/Rosenkranz
- PTO says no and the Board affirms
- CCPA disagrees
 - the claimable process is itself useful even if there is no use for the resulting output of the process

Brenner v. Manson

- Manson's arguments for utility
 - The claimed process makes a known compound, i.e., the process produces the result intended and such result is not detrimental to the public interest
 - Should this standard by itself be sufficient to meet the utility requirement?
 - The resulting compound is generally useful for scientific investigation and research
 - The resulting compound is useful as a possible object of future scientific inquiry
 - The resulting known compound should be deemed useful because it is a "homologue" (similar in a specific, chemically defined way) to a compound that has shown some effectiveness in treating tumors in mice

Brenner v. Manson

- Homologue argument
 - Problem is **unpredictability** in the steroid field countering the typical ability to predict the behavior of homologues
- General use for research / intended result arguments
 - Too broad a meaning for “useful” to take Story’s language to mean that an invention is useful if it is not positively harmful
 - Worries about the notice function and scope of the claims inform the analysis
 - since the patent needs to put people on notice of claimed subject
 - need specific benefit (describable) in currently available form
 - without this, insufficient justification to permit patentee to engross what may prove to be a broad field
- “But a patent is not a hunting license. It is not a reward for the search, but compensation for its successful conclusion.”
 - “A patent system must be related to the world of commerce rather than to the realm of philosophy.”
 - But note: Invention need not be in a commercially ready form for patenting.

Brenner v. Manson - Harlan

- Wants to reject narrow definition of “useful” and follow the CCPA
- The majority is mixing up
 - Issues of claim scope and interpretation with usefulness
- Majority’s focus on completion of search begs question of whether generating an intermediate research object is “useful”
- Focus on drafting techniques minimizing positive disclosure effects is not a problem limited to this patent or class of inventions
- Negative impact of majority’s decision on chemical research, less incentive to patent and disclose intermediate research outputs

Brenner v. Manson - Implications

- Useful versus “known to be useful”
- Later discovered uses
 - Iodine, nitroglycerine
- Is usefulness effectiveness?
 - Federal Circuit - it is possible for an invention to be less effective than existing devices, yet still meet the usefulness criteria
- Research Tools: other perspectives
 - Is it a process that produces a product that is: an object “of further research” or “for further research”?
 - Or “research on” (e.g., intermediate chemical) vs. “research with” (e.g., microscope)

In re Fisher – ESTs

- “An Expressed Sequence Tag is a tiny portion of an entire gene that can be used to help identify unknown genes and to map their positions within a genome.”
- “ESTs are powerful tools in the hunt for known genes because they greatly reduce the time required to locate a gene.”
 - <http://www.ncbi.nlm.nih.gov/About/primer/est.html>

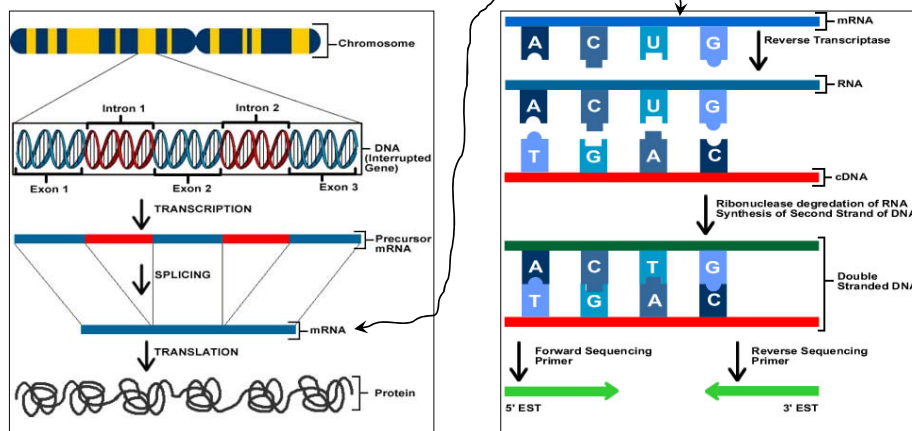

In re Fisher

- But like *Brenner v. Manson*, the applicant could not discern any use of the claimed ESTs that did not require further research to determine a “specific benefit” to the public
 - Products of claimed invention require further research “on” vs. research “with”
 - But a bit tougher than Manson, since it is the gene, not the EST that is the subject of the argument

In re Fisher

- Applicant argues court should return to *Lowell v. Lewis* and that “commercial success” shows utility
- CAFC rejects both arguments
 - “Specific benefit” must exist in “currently available form”
 - Must be “immediate benefit to the public” (emphasis added)
- Relies on MPEP
 - Manual Patent Examining Procedure
 - Not binding, but “may be given judicial notice to the extent they do not conflict with the statute”
 - Statute – Regulations – MPEP

In re Fisher

- Question is whether underlying genes have a “known function”
 - ESTs are merely “research intermediates that may help scientist to ... conduct further experimentation on those genes” (emphasis added)
 - Microscope is different – “immediately reveals” structure
 - But: Scientists directly conduct research “with” microscopes
 - But can scientists conduct research “with” ESTs?
 - Yes, but the relevant inquiry is the gene product, not the EST itself.
 - Underlying fear here that scientists will engage in “patent races” and lock up all sorts of ESTs without finding a concrete end-use

In re Fisher

- Judge Michel arguably goes awry in arguing that policy concerns over follow-on research or administrative concerns of the PTO should not “be considered in deciding whether the application ... meets the utility requirement” ... or the “requirements set forth in ... 101, 102, 103, and 112.”
- Indeed, the entire logic of Brenner rested on policy considerations.
 - Indeed, the whole “hunting license” point is that patents on inventions with uses only as “objects of further research” would impede the “Progress of the useful Arts”

In re Fisher (Rader, J., dissenting)

- States that ESTs are “research tools” like microscopes
 - Not exactly: See earlier arguments
 - Essentially repeats Justice Harlan’s argument in Brenner
- Ultimately comes down to an empirical question:
 - Would patents on “research intermediates” promote or hinder innovation?
 - Lock up valuable resources (Fortas) vs. Denies incentives for “incremental” innovation (Rader)
 - No to little empirical research on this question
 - Query: If both arguments are sensible, what should be the default rule? Pro-patents or anti-patents?