

Patent Law

- Slides for Module 4
- Anticipation, Statutory Bars and Novelty

Novelty and Statutory Bars (patent defeating events) in §102

- Novelty
 - sections (a), (e) & (g)
 - the **age** of the reference is earlier
 - “keyed” to the date of invention
 - “first to invent” priority system
- Statutory Bars
 - sections (b) & (d)
 - §102(d) - US application not filed w/in 1 year of foreign application on the same invention, which foreign application ultimately ripens into a foreign patent right before the US filing date
 - In other words, if one files in a foreign jurisdiction, after 12 months pass, one is at risk of being barred in the US if one does not file in the US before the foreign patent right issues
 - if I delay I am **barred**
 - “keyed” to the filing date
- Other patent-defeating events
 - abandonment - §102(c)
 - derivation - §102(f)

Novelty / Statutory Bar– structure of analysis

- Two step inquiry
 - First, assess the [current] state of knowledge known to the art as a basis for comparison
 - Must determine which sources from the universe of available knowledge are pertinent to the inquiry
 - Pertinent sources are defined by the patent act – called references
 - Prior Art is the sum of these references
 - Second, ask whether any references anticipate
 - Anticipate means:
 - each and every element of the claimed invention must be disclosed in a single, **enabling** reference
- A reference is enabled for **anticipation** purposes when it teaches a POSITA the manner and process of making the subject matter in the reference covered by the claim

Enablement for Anticipation versus for Specification Support

- A reference is enabled for **anticipation** purposes when it teaches a POSITA the manner and process of making ~~and using~~ the subject matter in the reference covered by the claim

| § 112 ¶¶1-2 Language | Label (specification requirement tests) |
|---|--|
| <p>[¶1] The specification shall contain a written description of the invention, and of the <u>manner and process of making and using it</u>, in such full, clear, concise, and exact terms as to enable any person skilled in the art to which it pertains, or with which it is most nearly connected, to <u>make and use</u> the same,</p> | <p>Written Description requirement.</p> <p>Enablement requirement.</p> |
| <p>and shall set forth the best mode contemplated by the inventor of carrying out his invention.</p> | <p>Best Mode requirement.</p> |
| <p>[¶2] The specification shall conclude with one or more claims particularly pointing out and distinctly claiming the subject matter which the applicant regards as his invention.</p> | <p>Definiteness requirement.</p> |

Dates of Invention and Prior Art References

- “anticipating” references are part of the analysis for both novelty and statutory bar patent defeating events
- What is an “anticipating” reference? (answered different ways that mean the same thing)
 - The reference “has” all the elements of the claim
 - The claim covers what is disclosed by the reference (the disclosure must be enabled for anticipation purposes)
 - The claim reads upon (or “reads on”) the reference

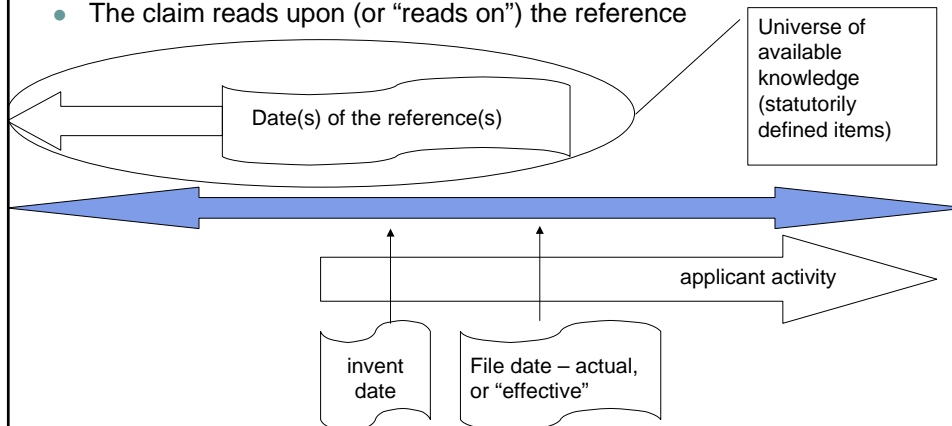



Patents, Spring 2008, Prof. Greg R. Vetter

OH 4.1.d

§102(a)

102(a) – if the prior art reference occurred prior to the date of invention of what is claimed, then the claim is not novel if that reference anticipates the claim (has all the limitations/elements of the claim).

| | | |
|---|-------------------------------|---|
|  | public knowledge or | “Public” is an implied requirement, relates to that segment of the public most interested in the technology, public if no deliberate attempts to keep it secret. |
| | used by others | One use is sufficient, even if private, remote or widely scattered, public if no deliberate attempts to keep it secret. |
|  | patented or | A grant of exclusive rights, evaluated for what is claimed, accessible to public & not secret |
| | printed publication | Public accessibility – the document was made available to the extent persons interested and ordinarily skilled in the art, exercising due diligence, could locate it. The test for what is a “patent or printed publication” is the same under 102(a) & (b). |



“the invention was known or used by others in this country, or patented or described in a printed publication in this or a foreign country, before the invention thereof by the applicant for patent”

Patents, Spring 2008, Prof. Greg R. Vetter

OH 4.1.e

§102(b)

102(b) – if the applicant does not file within one year of the date of the prior art reference or activity, then the patentee is barred from applying for the patent.

| | | |
|---|---------------------|--|
|  | in public use or | No purposeful hiding of use. Experimental use exception. |
| | on sale | Commercial offer for sale and invention is ready for patenting |
|  | patented or | same as 102(a). |
| | printed publication | same as 102(a). |

“the invention was patented or described in a printed publication in this or a foreign country or in public use or on sale in this country, more than one year prior to the date of the application for patent in the United States ”

Claims - Anticipation

When a claim “reads-on” a Prior Art reference, that reference anticipates the claim.

Put another way, whenever a Prior Art reference contains (explicitly or implicitly via the inherency doctrine) or all of the elements/limitations expressed by the claim, that Prior Art reference anticipates the claim

| | |
|---|--|
| Anticipating Reference (assume its prior)?? | |
| A drawing disclosing a stool with: A (a perfectly square seat) B (four legs) C (legs connected to the seat with steel nails) | A seating apparatus, comprising : 1. A (a horizontal base; and) B (three legs each having one end connected to the bottom of said horizontal base); and C (said connection between said legs and bottom of said horizontal base being a slim metal piece partially traversing some of said leg and said base, wherein the metal of said slim metal piece is brass, steel, iron, or tin) |
| A plant stand with: A (an oval base) B (two legs and a “wall”) C (legs connected to the base with glue) D (a “back” like a chair) | Same as above |

Claims - Obviousness

Unlike anticipation, to allege that a patent is “obvious” does not require that all the elements/limitations be in a single anticipating reference. Typically, the elements/limitations are spread over multiple references (but can be in one). The legal argument is that a POSITA would have found it obvious to combine the elements/limitations from multiple references.

| | |
|---|---|
| Is the invention obvious in light of the patent in view of the stool sold in the US? | A seating apparatus, comprising : 1. A (a horizontal base; and) B (three legs each having one end connected to the bottom of said horizontal base) and C (said connection between said legs and bottom of said horizontal base being a slim metal piece partially traversing some of said leg and said base, wherein the metal of said slim metal piece is brass, steel, iron, or tin) |
| A patent disclosing a stool with: A (seat) B (three legs) C (legs connected to the base with glue) | |
| A stool sold in the US with: A (seat) X (two “walls” on either side) Y (walls connected to the seat with metal screws) | |

Titanium Metals Corp v. Banner (Fed. Cir. 1985)

- Claims:
 - Titanium [Ti] base alloy consisting essentially by weight of **about** [see chart], balance titanium, said alloy being characterized by good corrosion resistance in hot brine environments

| | C1 (indep.) | C2 (dep.) | C3 (dep.) |
|-----------------|-------------|-----------|-----------|
| Nickel [Ni] | 0.6 – 0.9% | same | 0.8% |
| Molybdenum [Mo] | 0.2 – 0.4% | same | 0.3% |
| Iron | 0 – 0.2% | 0 – 0.1% | 0 – 0.1% |

- PTO (both examiner & Board) rejections – based on Russian Article
 - C1 & C2 – anticipated by the article
 - C3 – obvious from the article (obviousness is §103)
 - §103(a):
 - “[a] patent may not be obtained though the **invention is not identically disclosed or described as set forth in section 102 of this title**, if the differences between the subject matter sought to be patented and the prior art are such that the subject matter as a whole would have been obvious at the time the invention was made to a person having ordinary skill in the art to which said subject matter pertains . . . “
 - The §103(a) language informs the meaning of anticipation – “identically”

Titanium Metals Corp (“TMC”) v. Banner (Fed. Cir. 1985)

- Only §102 rejections are at issue on appeal
- What is the sole reference and is it prior?
 - Date of “invention” – at least 7/25/1975
 - Date of reference (Russian Article) – 1970
- So, if reference (article) is prior, the question is whether it discloses the elements/limitations of the claim
 - “Since the article does not specifically disclose such an alloy in words, a little thinking is required about what it would disclose to [a POSITA]”

Titanium Metals Corp v. Banner (Fed. Cir. 1985)

- PTO contended that a sole point disclosed the claimed combination
 - Mo:Ni at 1:3 is indicated on the graph at 1% for Mo + Ni by the point indicated
 - This equates to Mo & Ni values within the claimed ranges of C1 & C2
- Further, the PTO contended:
 - the fact that a property or end use (as contemplated by applicant) was not recognized by the article is of no consequence
 - the article did discuss other related properties such as strength and ductility
 - the authors of the article likely made the alloys to obtain the graph points

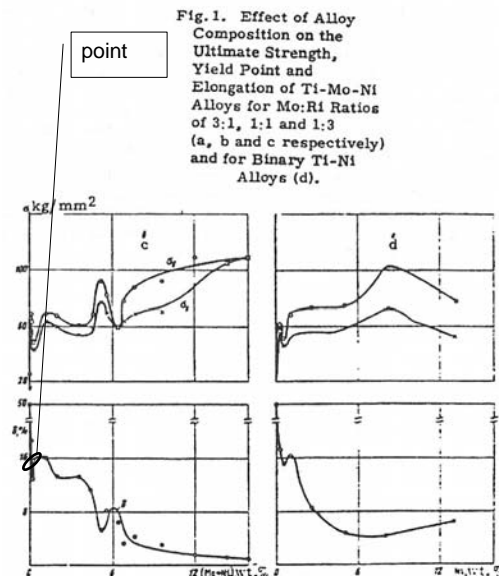

Titanium Metals Corp v. Banner (Fed. Cir. 1985)

- Holding
 - It starts with a “pun”
 - “[the fact that the application discloses knowledge beyond what the article discloses] is beside the **point.**”
 - District court fails to answer the question – is the claimed alloy new?
 - Given the date of the reference, either §102(a) or (b) applies here (5 years prior)
 - The Federal Circuit agrees with the PTO as to the disclosed data point indicating the presence of Mo and Ni in the claimed ranges
 - Enablement only requires that a POSITA be able to make the alloy
 - The article does not discuss making the alloy, it merely gives the ingredients and proportions, but this is not a problem because this is all a POSITA would need to know
 - It is of no import that the application teaches some things that the article does not (corrosion resistance, limits of ranges to keep this property)
 - When a claim covers several compositions, via ranges or otherwise, the claim is anticipated if even one composition or value in the range is in the prior art

Anticipation – other points

- Four corners defense
- Genus / Species cases
 - Special problem when inventor claims some subset of a known broader range – species chosen from genus
 - Applicant must demonstrate that the species has improved or distinct properties over other members of the prior art genus
 - 6 factors, page 169

Inherency – Continental Can (Fed. Cir. 1991)

- '324 patent for Ribbed bottom structure for plastic container
- Bottom has flexibility for better impact resistance, yet sufficient rigidity to resist deformation under internal pressure

FIG. 2

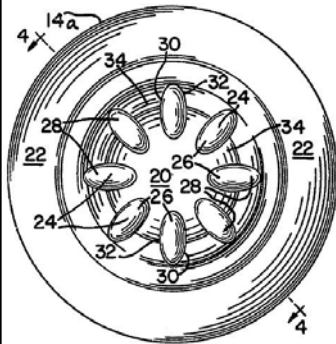

Patents, Spring 2008, Prof. Greg R. Vetter

| | |
|--|-----|
| 1. A container having | |
| a sidewall and | A |
| a bottom structure closing the container at an end portion of the sidewall, | B |
| the outer surface of the bottom structure comprising a central concavity, | C |
| a convex heel surrounding the concavity and merging therewith and with the sidewall end portion, the lowermost points of the heel lying in a common plane, and | D |
| a plurality of ribs interrupting the outer surface of the concavity and distributed in a symmetrical array, | E |
| each rib extending longitudinally in the direction of the heel and downwardly from an inner portion of the concavity, | E.1 |
| whereby the outer end portion of each rib is lower than the inner end portion thereof, | E.2 |
| <i>characterized by the feature that the ribs are hollow</i> | E.3 |

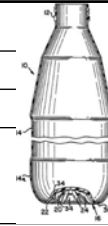

page 171-175

OH 4.4.a

Inherency – Continental Can (Fed. Cir. 1991)

- District court held patent invalid for anticipation
 - It defined “hollow” as the inside contour of the ribs generally following the outside contour thereof (parties agreed to this definition)
 - How else might one define “hollow”
- Federal Circuit reverses
 - Conflicting experts along the “party lines” as to whether the prior art patent ribs were hollow
 - Prior art patent inventor testified that conventional blow molding would make them hollow as a natural or automatic result of the blow molding process
 - Claim construction of the term “hollow”

Patents, Spring 2008, Prof. Greg R. Vetter

page 171-175

OH 4.4.b

Claim Interpretation – Sources / Canons

| “hollow” | | |
|--|---|--|
| District Court: “the inside contour of the ribs generally follows the outside contour thereof” | | |
| <u>Source</u> | | |
| Plain meaning | 1. Having a cavity, gap, or space within: <i>a hollow wall</i> . 2. Deeply indented or concave; sunken | American Heritage Dictionary |
| Specification | Distinguished the precise prior art patent asserted as anticipating, on the basis that the prior art patent’s ribs were filled, not hollow | The specification can be used to enlighten the court as to the meaning of a claim term |
| Prosecution history | None provided here | Effect on claim construction? |
| Extrinsic Evidence | Expert testimony could go to what “hollow” means to a POSITA, here it was directed to informing the fact finder in making a determination as to whether the prior art reference’s ribs met the definition of hollow | Proper to resort to extrinsic evidence? |

Patents, Spring 2008, Prof. Greg R. Vetter OH 4.4.c

Inherency – Continental Can (Fed. Cir. 1991)

- degrees of hollowness?

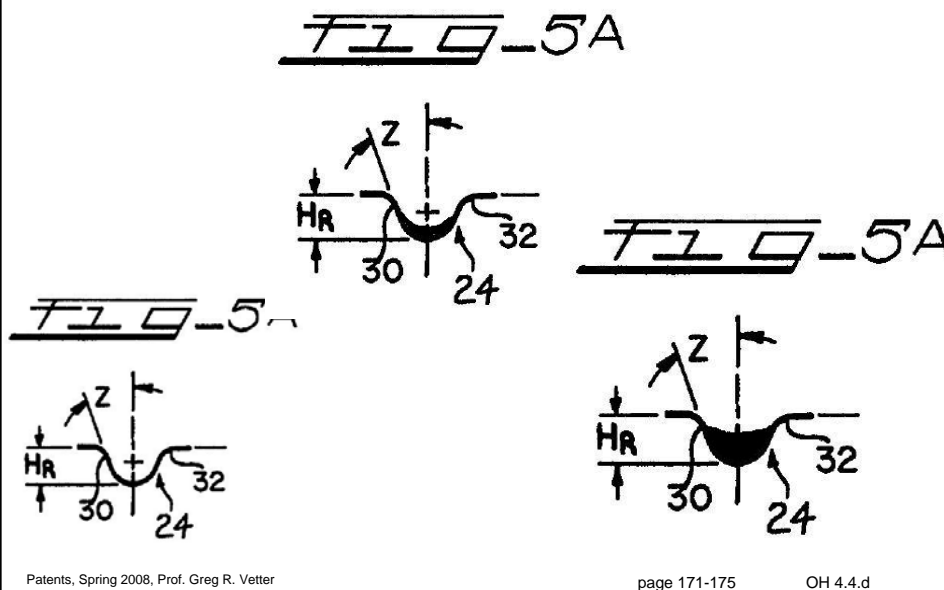

Inherency – Continental Can (Fed. Cir. 1991)

- Defendant (Monsanto) argues that the hollow ribs were inherently produced by the prior art patent (Marcus) – regardless of how shown in the patent
 - Injection blow molding would inherently produce hollow ribs
 - As evidence of this, Monsanto points to another patent, the Conobase '324 patent – where evidently hollow ribs result from blow molding
- The evidence to prove that a characteristic is inherently present “must make clear that the missing descriptive matter is **necessarily present** in the thing described in the reference, and that it would be so recognized by [a POSITA]”
 - Probabilities or possibilities are not enough
 - The “mere fact that [it] may result . . . is not sufficient”
- Justification for the inherency doctrine
 - Provides some flexibility to the anticipation rule when the common knowledge of technologists is not recorded in the reference

Inherency – Continental Can (Fed. Cir. 1991)

- Why would injection blow molding “necessarily” produce hollow ribs?
 - This would be the “natural result flowing from the operation as taught” by the reference
- Continental disputes whether hollow ribs “necessarily” follow, so there is a GIMF, and S/J should not have been awarded to Monsanto

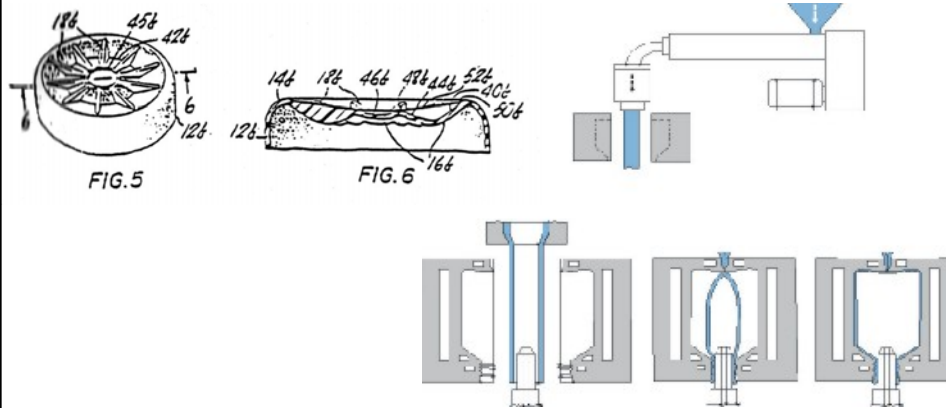

Inherency – additional points

- Consider these points from notes 1-3 in light of:
 - Schering Corp. v. Geneva Pharms., Inc., (Fed. Cir. Aug. 1, 2003) (Rader, J.)
 - Schering Corp. v. Geneva Pharms., Inc., (Fed. Cir. Oct. 28, 2003) (order)
- “accidental” uses
 - Relationship to the enablement standard for anticipation?
 - Or, are these merely “undetected” uses
- Undetectable uses – anticipation of Americium?
 - Minuscule amounts and bad conditions
- Does the POSITA need to recognize that structure or a method behaves according to a law of nature for an inherency finding?
 - For example, the first person to discover the necessity of oxygen to fire could not claim “a method of making a fire by lighting a flame in the presence of oxygen”
 - This method would be anticipated by prior occasions of making fires, regardless whether the “POSITA” making the prior fires understood that oxygen was necessary

Inherency – additional points

- Anticipation exercise
 - “DDS Catalog” should be “Fiendish Fluoridators”
 - what issue(s) are raised?
- Search is for prior art with two attributes:
 - bristles from NYLANON
 - specially-shaped handle that is easy to grip

The bigger picture – Novelty & NonObviousness

- A framework for contrasting the differences between novelty and nonobviousness, and noting the common reliance on prior art references

| | Novelty | Nonobviousness |
|---|---|--|
| What is the set of technical information that can be considered? | The information must fall within one of the paragraphs of §102 | Generally speaking, §102, although some significant exceptions exist |
| What is the standard of comparison between the claimed invention and the prior art? | An enabling disclosure of each and every element of the claimed invention | Nonobviousness as defined in §103(a) and construed in case law |

Patents, Spring 2008, Prof. Greg R. Vetter OH 4.10

Egbert v. Lippman (1881)

- How does Egbert deal with the following considerations in determining whether a use is “public use” under §102(b)?
 - Number of articles in use?
 - Number of users?
 - Significance of public observation?
 - Number of observers?
 - Extent to which observers understand the disclosed technology?
- Significance of efforts to keep it secret?
 - Presence or absence of a confidentiality agreement?
 - Can close personal relationships substitute?
 - Squaring with Moleculon Research [note 3, pg. 186-87]

Metallizing Engr. Co. v. Kenyon Bearing (2d. 1946)

- District court held the patent valid
 - It concluded under Peerless Roll that even though the use of the process for conditioning metal was primarily commercial (and any experimental use was subordinate), the use, being secret, was not “public use” and thus not patent defeating
 - In Peerless Roll the patented machine was operated secretly, its output sold openly, but the output disclosed no knowledge about the machine
- Based on weight of other precedent and policy, the court overrules Peerless Role and invalidates the Metallizing patent

Metallizing Engr. Co. v. Kenyon Bearing (2d. 1946)

- Other invalidating “public” precedent
 - Rubber hose joint-making process operated in secret but the hose was sold in significant quantity, and the resulting joints by themselves did not disclose the process
 - Harness making machine operated in secret but harnesses sold to public
 - etc. . . .
- The Metallizing holding then comes down to
 - Secret commercial exploitation of an invention by the inventor constitutes a “public use” under §102(b)

Metallizing Engr. Co. v. Kenyon Bearing (2d. 1946)

- A claim to either (i) a process to produce a product, or (ii) a machine which produces a product, may be invalid
 - due to a statutory bar patent defeating event
 - if the resulting product produced by the process or machine is used/sold publicly
- Why?
 - Using/selling publicly effects a commercial use of the invention even if the process or machine is operated in secret

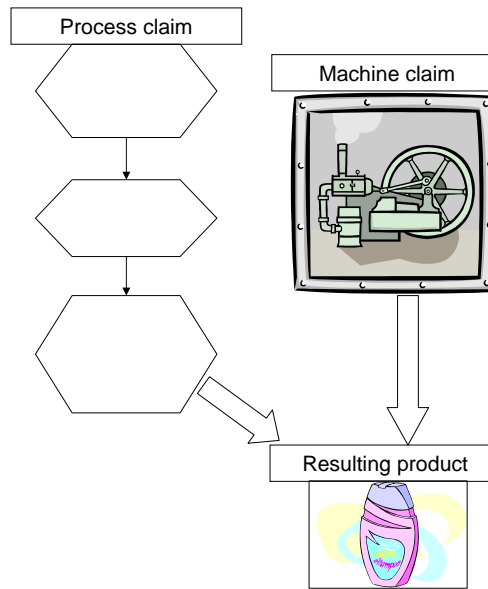

Framework for §102(b) public use

- Use three categories to sort the effect of the use of the invention
 - whether it informs the public or others of the invention
 - whether it does not so inform, or
 - whether the use was explicitly the subject of efforts to keep it secret
- The table below is for the following question:
 - *Is it a "public use" under §102(b)?*

| Actor | Informing Use | Non-informing Use | Secret Use |
|------------------|---------------|---------------------------------|---------------------------|
| Applicant | Yes | Yes <u>Egbert v. Lippman</u> | Yes <u>Metallizing</u> |
| Third Party (TP) | forthcoming | | |

City of Elizabeth v. Pavement Co. (1877)

- Experimental use doctrine
 - If the doctrine applies, then the use is not a patent defeating statutory bar event under §102(b)
- Fundamental inquiry
 - ***is the use necessary to demonstrate workability of the invention, i.e., suitability for its intended purpose***
- Does doctrine apply to Mr. Nicholson's road pavement invention?
 - Abandonment is not the issue here, although abandonment can occur during the §102(b) "grace" period

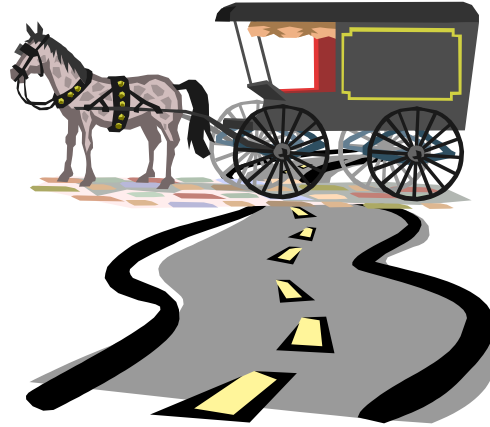

City of Elizabeth v. Pavement Co. (1877)

- Must experiment on street pavement in public
 - Some experiments, such as for durability, may take time
- A use is not a "public use," even if the public benefits, if the use is still an experiment
- Nicholson's situation
 - He controlled the experiment, had consent and performed it on the premises of the company he had some influence over
 - Experiment had the valid purpose of testing for durability and needed the public venue to properly test this characteristic
 - While it was a long test, the length seems reasonable
 - Users did not pay any additional amounts for the use of the invention, the road was already a toll road
 - Mr. Nicholson was constantly inspecting the road and monitoring its performance, asking the toll gate operator how travelers liked it



Experimental Use factors

- Factors for experimental use exception to public use statutory bar – to help determine whether the experiment is leading to an actual reduction to practice:
 - Control by inventor (most important)
 - Confidentiality / secrecy agreements
 - Necessity of public testing
 - Length of test period, number of prototypes
 - Did users pay? Commercial exploitation?
 - Progress reports, monitoring, records of performance
 - The experiment must be for claimed features of the invention, or perhaps for general purpose/utility of the invention [note 3, pg 197]
 - Are experiments hidden?
- Is experimental use an exception or part of the “public use” inquiry, i.e., a “negation”? [note 2, pg 196-97]
- Does market testing for customer satisfaction qualify? [note 5, pg 198]
- Emphasis on control and customer awareness [Electromotive Div. of GM v. Transportation Sys. Div. of GE, 417 F.3d 1203 (Fed. Cir. 2005)]

Experimental Use – other items

- Manville Sales v. Paramount Sys (Fed. Cir. 1990)
 - The context of the sale was as an experiment
 - Manville told a Wyoming official it was an experiment
 - confidentiality notices on drawings ensure no disclosure
 - Manville did not try to exploit the invention until March 1972, after the inspection showed a successful winter
 - Even though Manville was paid, the sale was primarily for experimental purposes
 - Manville’s actions are consistent w/ prompt disclosure – w/out the testing the invention is not worth disclosing anyway

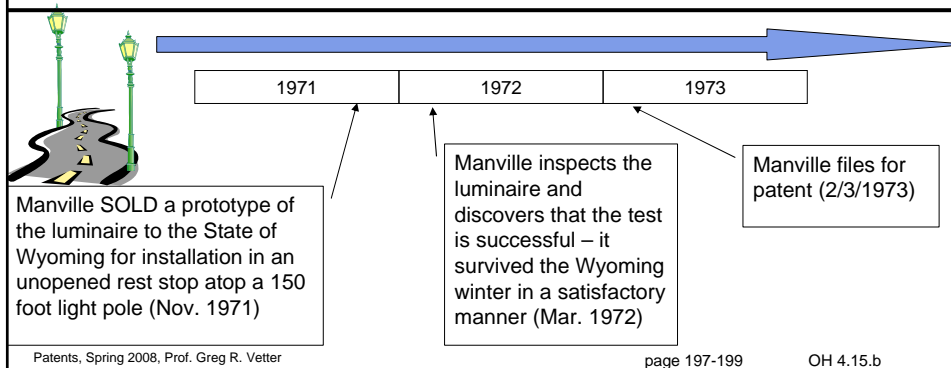

Lough v. Brunswick (Fed. Cir. 1996)

- Lough built 6 prototypes for a new seal for Brunswick inboard/outboard drive, and during 1986 distributed them as follows
 - He installed one in his own boat
 - He installed one in a friend's boat
 - He installed one in the boat of the co-owner of the dealership where he worked
 - He installed one in a customer of the dealership
 - He gave the last two to a friend, who installed one in the boat of a local charter, and another in a marina demo boat that was later sold
- Lough's filing date is June 6, 1988.

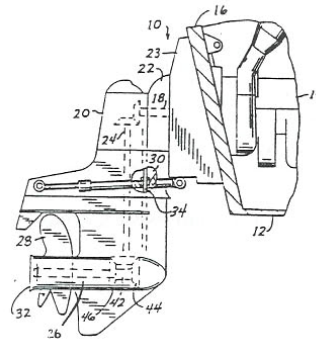

Lough v. Brunswick (Fed. Cir. 1996)

- Public use includes
 - “any use of [the claimed] invention by a person other than the inventor who is under no limitation, restriction or obligation of secrecy to the inventor” and depends on “how the totality of the circumstances of the case comports with the policies underlying the public use bar”
- These policies are:
 - (1) discourage removal of inventions the public reasonably may believe are freely available;
 - (2) favoring prompt and widespread disclosure;
 - (3) allowing a reasonable time following initial sales to assess economic potential; and
 - (4) prohibiting commercial exploitation beyond the statutory time



Lough v. Brunswick (Fed. Cir. 1996)



- Rader: "plastic malleability of a Totality of the Circumstances test"

| Factor | Majority | Rader |
|--|--|---|
| Control by inventor (most important) | no follow-up provisions when providing seals to friends (one seal installed in a boat later sold to strangers) | Close personal relationships could suffice, mere participation by others does not equate to no control |
| Confidentiality / secrecy agreements | | Close personal relationships could suffice |
| Necessity of public testing | | Necessity of testing under various circumstances militates against full control requirement |
| Length of test period, number of prototypes | | Short test period, small # of prototypes |
| Did users pay? Commercial exploitation? | None. | None, but the court gave this too little credence |
| Progress reports, monitoring, records of performance | No test records or data, did not inspect other installations | Lough took photographs (more than some cases) |
| The experiment must be for claimed features of the invention, or perhaps for general purpose/utility of the invention [note 3, pg 197] | | Tests carefully tailored to the nature of the invention |
| Are experiments hidden? | | Invisible use adds plausibility to the need to take few additional precautions to protect confidentiality |

Patents, Spring 2008, Prof. Greg R. Vetter page 199-211 OH 4.16.c

Lough v. Brunswick (Fed. Cir. 1996) – negation or exception?

- Significance of (i) majority characterizing the issue as a Question of Law (QofLaw), and (ii) the implicit burden shifting alleged by Judge Rader in making the issue a separate legal test with its own factors.

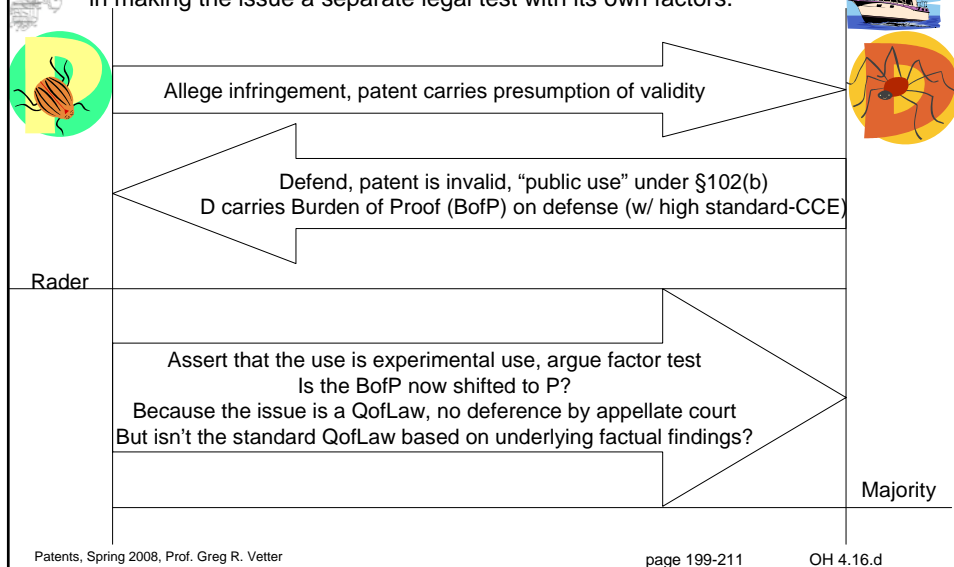

On Sale Bar – §102(b)

- Subject of a commercial sale or offer for sale
- Intention is “ready for patenting,” i.e., it is “complete,” satisfied in either of two ways:
 - Actual Reduction to Practice
 - invention in existence and proven to operate for its intended purpose
 - This could mean it has been “built” or could be met though other forms of evidence
 - OR
 - “Ready for patenting”
 - Sufficiently specific information is available to prove that the invention is fully conceived, such as drawings, technical descriptions
 - Must enable a person skilled in the art to practice the invention.
 - Analogous to a “Constructive Reduction to Practice” – a term sometimes used to refer to the filing of a patent application

Pfaff v. Wells Elec. (1988)

- Pfaff invents new socket for Texas Instruments (TI)
 - His normal practice is not to make or test a prototype before offering to sell it in commercial quantities
 - District court rejects Wells’ §102(b) On Sale Bar (OSBar) defense

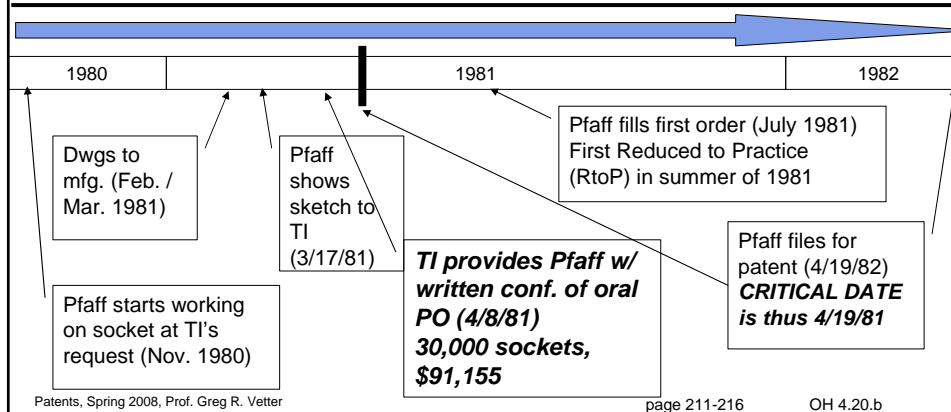
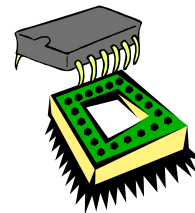

Pfaff v. Wells Elec. (1988)

- Federal Circuit Opinion
 - Four of Six claims are invalidated by OSBar
 - The remaining two claims are invalid under the obviousness test when the four invalidated claims are considered as prior art references
 - If invalid under the OSBar, these 4 claims would be Prior Art to the two remaining claims

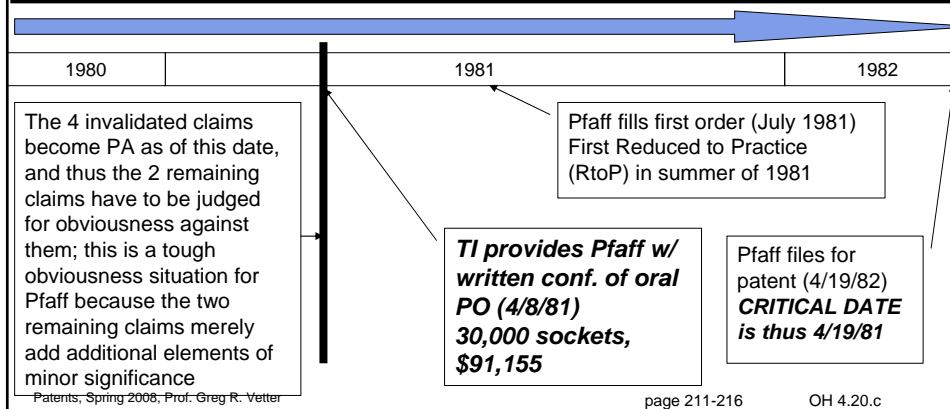
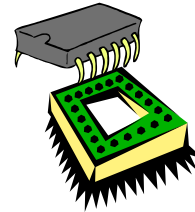

Pfaff v. Wells Elec. (1988)

- Supreme Court
 - Well settled that an invention may be patented before an Actual Reduction to Practice (ARtoP)
 - Only reference to term RtoP in statute is §102(g)
 - This reference demonstrates that the date of the patent right is keyed to the conception date
 - To file without an ARtoP, the filed application must meet the Specification Requirements (enablement, written description, best mode, definiteness), but this does not always require building a prototype

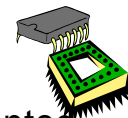

Pfaff v. Wells Elec. (1988)

● Supreme Court

- Pfaff could have patented the invention at the time of the PO
 - The drawings Pfaff provided to the manufacturers described the invention with “sufficient clearness and precision to enable those skilled in the matter” to produce the invention
 - Thus, the invention was “ready for patenting” at the time of the PO
- However, even though Pfaff loses, the Supreme Court agrees that the Federal Circuit’s “substantially complete” Totality of the Circumstances (TofC) test is the wrong standard
- Inventor can both understand and control the timing of the first commercial marketing of the invention
- Here, there was a commercial offer for sale by Pfaff, a response from TI with a purchase order, and an acceptance; all at a time when the invention was “ready for patenting”

On Sale Bar – other items

● Federal Circuit application

- How does the Pfaff test impact the requirement that the subject matter be covered by the claim?
 - Scaltech – “if the process that was offered for sale inherently possessed each of the claim limitations, then the process was on sale” (revision to opinion post-Pfaff)
 - Applying the anticipation rule, that the subject matter on sale must meet every element of the claim, should the inherency doctrine be a part of that analysis in an OSBar situation?
- Is the enablement standard of the Pfaff “ready for patenting” test inconsistent with or consistent with an approach that requires the subject matter to possess each claim element/limitation?
 - Is the “ready for patenting” test a “sufficiency” test (expressed in terms of enablement) for the level of evidence necessary when there has not been an ARtoP?

On Sale Bar – other items

- Group One 254 F.3d 1041 (Fed. Cir. 2001)
 - Under Group One, interpretation of *Pfaff*'s commercial offer-for-sale prong thus requires the application of traditional contract law principles to the facts of the particular case. Because the on-sale bar involves questions of patent law requiring national uniformity, Group One declined to rely on the law of the particular state in which the transaction occurred, instead holding that the existence of an offer for sale should be analyzed "**under the law of contracts as generally understood.**" Group One, 254 F.3d at 1047, 59 USPQ2d at 1126.
 - Group One further instructs that the Uniform Commercial Code ("UCC") should inform the analysis of the contractual issues. *Id.* ("As a general proposition, we will look to the Uniform Commercial Code ('UCC') to define whether, as in this case, a communication or series of communications rises to the level of a commercial offer for sale."). Of course, the UCC is a model code-it does not itself have the force of law and no body of case law has explored its provisions. Instead, it has been enacted with modifications in the several states. Thus, the body of case law from which we must draw guidance under Group One is that of the state and federal courts interpreting their individual versions of the UCC. From this body of state law, **we will search for the common denominator** for assistance in crafting the federal common law of contract that now governs the on-sale bar.
 - Linear v. Micrel, 275 F.3d 1040 (Fed. Cir. 2001)

On Sale Bar – HYPO

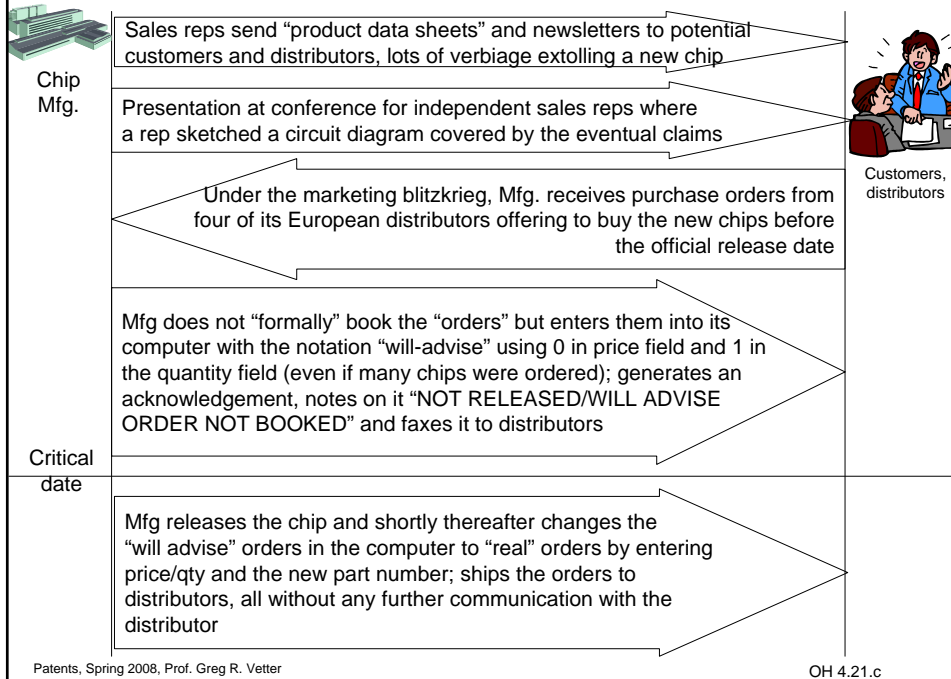

On Sale Bar – How far to take the contract law test

The Patent Act precludes the issuance of a patent if “the invention was . . . on sale in this country, more than one year prior to the date of the application for patent.” 35 U.S.C. 102(b). Since the 1800s, the federal courts have uniformly held that this “on-sale bar” is triggered by the inventor’s “commercial marketing” of his invention, such as through advertising and the solicitation of orders from customers. This doctrine prevented inventors from exploiting their inventions through commercial activity without promptly filing a patent application.

The Question Presented is whether the Federal Circuit erred in abrogating the settled understanding that the on-sale bar of 35 U.S.C. 102(b) arises from commercial marketing of an invention in favor of a test that limits the bar only to circumstances in which the inventor has made a “formal offer” for sale, *i.e.*, an offer which “the other party could make into a binding contract by simple acceptance.”

Petition for Certiorari - Linear v. Micrel (not granted, but Solicitor General invited to submit a brief)

On Sale Bar – other items

- Sale of patent rights
 - “Although the formal written assignment occurred after the critical date, the district court held that even if there were an earlier oral agreement, an assignment or sale of the rights in the invention and potential patent rights is not a sale of “the invention” within the meaning of section 102(b). We agree. The few cases we have found on this issue have uniformly held that such a sale of patent rights does not come within the section 102(b) bar. Such a result comports with the policies underlying the on sale bar, and with the business realities ordinarily surrounding a corporation’s prosecution of patent applications for inventors” Moleculon [note 3. pg 217-18]
- Sales to related parties
 - Standard is whether the seller “so controlled” the purchaser that the invention stays out of the public’s hands
 - In one case, 50% ownership in an exclusive distributor was not sufficient



Framework for §102(b) public use bar

- Use three categories to sort the effect of the use of the invention:
 - whether it informs the public or others of the invention
 - whether it does not so inform, or
 - whether the use was explicitly the subject of efforts to keep it secret
- The table below is for the following question:
 - Is it a "public use" under §102(b)?

| Actor | Informing Use | Non-informing Use | Secret Use |
|------------------|---|---|---|
| Applicant | Yes | Yes <u>Egbert v. Lippman</u> | Yes <u>Metallizing</u> |
| Third Party (TP) | Yes Manufacturing of a fine lead powder where the employees and customers were openly shown the process and machines | Yes? Area of greatest uncertainty; such uses are clearly patent defeating for the on-sale bar, and thus would likely be defeating for the public use bar | No Also area of some uncertainty, but for our purposes, if use is held secret, for example, as a trade secret (TS), such use is not barring when done by a TP; example fact pattern is a manufacturing process or machine sold w/ TS clause requiring buyer to hold it as a TS |

Patents, Spring 2008, Prof. Greg R. Vetter OH 4.21.f

§102(a) & §102(b)

| | | |
|---|---|--|
|  | ... | |
|  | patented or printed publication | <p>A grant of exclusive rights, evaluated for what is claimed, accessible to public & not secret</p> <p>Public accessibility – the document was made available to the extent persons interested and ordinarily skilled in the art, exercising due diligence, could locate it.</p> <p>The test for what is a "patent or printed publication" is the same under 102(a) & (b)).</p> |

Meaning for foreign jurisdictions?

Meaning?

Patents, Spring 2008, Prof. Greg R. Vetter OH 4.22

§102(a) & (b) - "Patented" – In Re Carlson (Fed. Cir. 1992)

- Does a German Geschmacksmuster [design patent] constitute an "invention . . . patented . . . in . . . a foreign country"?
- The Geschmacksmuster registration
 - effective on deposit at Amtsgericht [district court]
 - some information provided in Bundesanzeiger [federal legal gazette]
 - a full, certified copy is held in the city of Coburg
- On reexam, the PTO invalidated Carlson's design patent for a dual compartment bottle in light of a German Geschmacksmuster
- Federal Circuit affirms



FIG. 3

§102(a) & (b) - "Patented" – In Re Carlson (Fed. Cir. 1992)

- Standard of knowledge charged to the objective, fictional POSITA
 - knowledge of all the contents of relevant Prior Art
 - regardless of the actual knowledge of the applicant
 - The fictional POSITA's "charged knowledge" of the Prior Art includes knowledge of "patents" in a "foreign country"
 - As long as such "patents" are "**available to the public**"
 - secret/private patents do not qualify as "patented" abroad
- This standard defeats Carlson's arguments:
 - The foreign patent must be readily accessible to qualify as such
 - Here there was only a deposit of a model in a city courthouse in a foreign land
 - The gazette entry does not mention dual compartment containers, so there is no notice
- The Court notes that
 - the German gazette entry refers to a single package incorporating multiple plastic bottles
 - Thus, there is some notice
 - Even a single deposit in a local courthouse in a foreign land is "available to the public"



FIG. 3

Design Patent Examples

- Scanner
- Shrimp Tray
- Toy Robotic Shrimp



§102(a) & (b) - "Patented"

- Is the German design patent more like © protection than patent protection?
- Other German "patent" type – Gebrauchsmuster [utility model]
- Hypo:

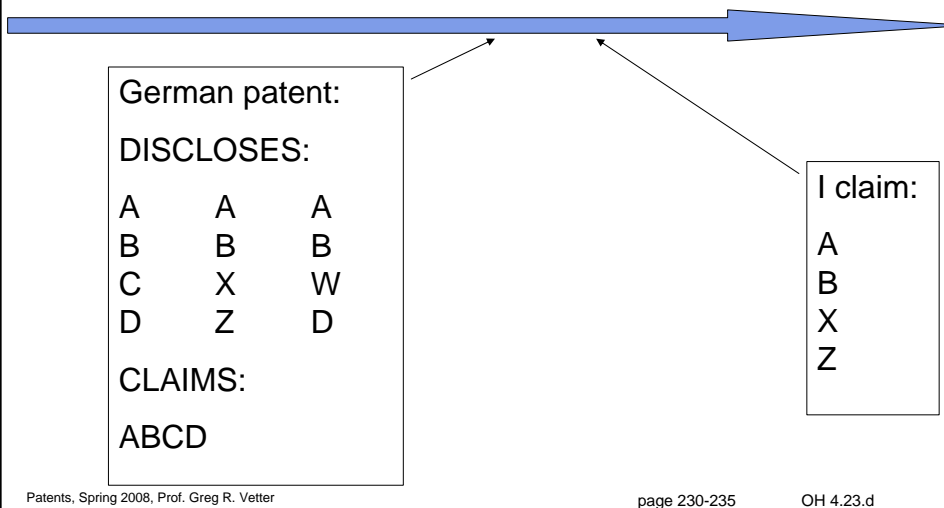

§102(a) & (b) - “Printed Publication” – In Re Hall (Fed. Cir. 1986)

- Hall’s effective filing date is 2/27/79
- During September 1977 the anticipating doctoral thesis of Dr. Foldi was submitted to the Dept. of Chemistry and Pharmacy at a university in Germany
- German library says that its dissertations are made available to the public by being cataloged, indexed and placed in the collection
- Dr. Foldi’s thesis was likely available for general use during December 1977
 - This is based on library’s estimation of its typical timeliness in processing received dissertations
 - The known date of receipt was in November, 1977
- Implications if the library’s estimate is incorrect by 3 months?
 - This would put the library cataloging/indexing of the dissertation into March 1978 – how would this impact the outcome?

§102(a) & (b) - “Printed Publication”

- Other fact patterns [note 3, pg. 239]
 - Undergraduate thesis (In re Cronyn)
 - Not meaningfully indexed (cards in a box, not in library computer system), thus not a “printed publication”
 - Type written paper presented at conference (Deep Welding)
 - Perhaps not a “printed publication” because not indexed or cataloged?
 - Unless - the conference constituted much of the “relevant public”
 - Court found that the reference was a “printed publication” because
 - “printed” does not necessarily mean typesetting or other formal printing processes
 - This publication was publicly distributed at conferences of POSITAs
 - Foreign patent application on microfilm [“printed”?] (Phillips)
 - “as indexed, [it] was available to persons interested and could be located by persons ordinarily skilled in the subject matter with the exercise of reasonable diligence”
 - This is a good statement of the diligence standard embedded in the inquiry

§102(a) & (b) - “In this Country” – Ex parte Thompson (BPAI 1992)

- Claim 1 is for “a cotton cultivar having the designation Siokra . . .”
 - dependent claim 2 is for the seeds
- Prior Art under 102(b) must
 - (i) sufficiently describe the claimed invention to have placed the public in possession of it; and
 - (ii) such possession is effected if a POSITA could combine the publication’s description w/ his or her own knowledge to make the claimed invention [in effect implementing the enablement standard for anticipation]

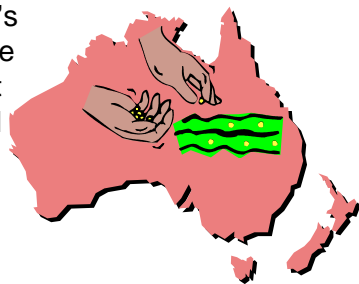
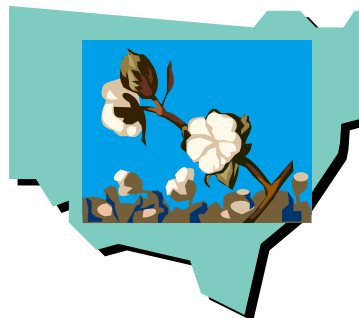

§102(a) & (b) - “In this Country” – Ex parte Thompson (BPAI 1992)

- Here, the publications describe the Siokra plant in Australia
 - Enablement occurs because seeds are available in Australia
 - The publications describe the seeds and document their commercial availability
 - A POSITA would know to buy the seeds, plant and grow them!! – which would be sufficient to “make” the claimed Siokra
 - Applicant is not claiming a method to produce Siokra

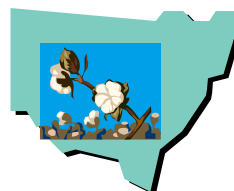

§102(a) & (b) - “In this Country” – Ex parte Thompson (BPAI 1992)

- Applicant says that this incorrectly combines the public use bar and the printed publication bar
 - Does it?
- What is the policy behind the territorial dichotomy?
 - perceived difficulty of learning about unpublished developments overseas?
 - Thus, a geographically based standard of what inventors should be held to know
 - Does modern communication and transportation make the US system outmoded? Unfair?

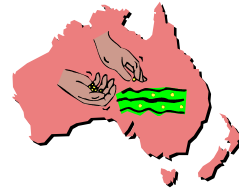
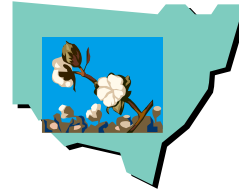





§102(a) & (b) - “In this Country” HYPO [note 4, pg. 243]

- Method “routing” claim implemented in software in a phone switch in Mexico, operated for more than 1 year before the critical date
 - Many of the calls originate in the US
- Is 102(b) a patent defeating bar?
- Is this use a “public use”?
 - Is it informing, non-informing, or secret?
- Is it “in this country”?



HYPO - §102(a) & (b) - "printed publication"

| | Day 1 | Day 10 | Day 368 | Day 385 |
|--|---|---|---|---|
| | Speech: A B C D | Article in German language, published in scientific newspaper in Germany: A B C D | File in US for: A B C D | File in US for: A B C D |
| |  |  |  |  |
| Players | §102(a) | | §102(b) | |
| A & C | <u>Different:</u> C is not novel based on C's f/d <u>Same:</u> 102(a) is not patent defeating because the article is not before the inventor's date of invention | | <u>Different:</u> C is barred <u>Same:</u> C is barred | |
| A & B | <u>Different:</u> B is not novel based on B's f/d <u>Same:</u> 102(a) is not patent defeating because the article is not before the inventor's date of invention | | <u>Different:</u> B is not barred <u>Same:</u> B is not barred | |
| Patents, Spring 2008, Prof. Greg R. Vetter | | | f/d = file date | OH 4.26 |

§102(c) Abandonment

- Statute:
 - A person shall be entitled to a patent unless . . . (c) he has abandoned the invention
 - Meaning
 - surrender of the invention **to the public**
 - Certain conduct by the inventor can lead to the forfeiture of the right to obtain a patent on the invention
- Kendall v. Winsor (US 1858) – inventor can confer benefits of the invention to the public by express declaration **or** by conduct equally significant with language, such as
 - acquiescence with full knowledge
 - willful or negligent postponement of filing, or
 - by waiting to patent until others introduce the invention
- In Kendall v. Winsor, the communications to the D were not to the public

§102(d) Delayed US Filing

- Statute:

- A person shall be entitled to a patent unless . . . (d) the invention was first patented or caused to be patented, or was the subject of an inventor's certificate, by the applicant or his legal representatives or assigns in a foreign country prior to the date of the application for patent in this country on an application for patent or inventor's certificate filed more than twelve months before the filing of the application in the United States

- Meaning:

- the patent defeating bar operates if
 - an inventor files a foreign patent application more than 12 months before filing the US application
- and
 - a foreign patent results from that foreign application prior to the US patent filing date

§102(d) Delayed US Filing

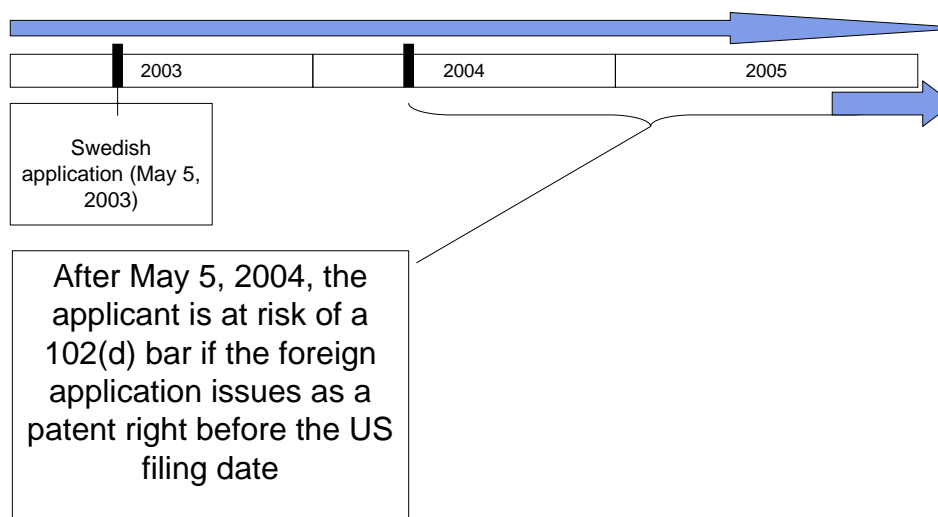

§102(d) Delayed US Filing

- In re Kathawala (Fed. Cir. 1993)
 - Spanish and Greek applications filed and issued before US f/d, and US f/d more than a year after both foreign filing dates
 - Issue is whether there are other reasons to not consider the Spanish or Greek applications barring
 - Kathawala argued:
 - Spanish application was not barring because it merely claimed a method of making
 - Greek law disallowed patents on pharmaceuticals

| Country | Compound Claims | Pharma. Composition Claims | Method of Making Claims | Method of Using Claims |
|---------|-----------------|----------------------------|-------------------------|------------------------|
| US | X | X | | X |
| Greece | X | X | X | X |
| Spain | | | X | |

Statutory Bar Exercises

???

1. Unstrung Incorporated begins development efforts to adopt Bjorn's process to the realities of the factory production line on August 1, 2001. After modifying its existing manufacturing processes to fit the Bjorn process and working out the bugs, Unstrung judges these efforts to be successful by November 19, 2001. At that point, Unstrung then begins commercial production.

2. A few days after completing her invention, Bjorn writes an article about the process and submits it to a technical journal. The article is published on December 15, 2001.

3. Unstrung Incorporated begins shipping tennis rackets produced by the Bjorn process to distributors on February 1, 2002. Retailers makes the first sales of Bjorn-produced rackets to consumers by February 10, 2002.

4. An unrelated party located in the United States, Swish Limited, had developed a similar process to that invented by Bjorn. Swish perfected the process on October 7, 2001, and produced several dozen rackets. Ultimately, however, they decided not to employ the process on a larger scale for financial reasons. Swish maintained the process documentation and resulting rackets under lock and key, and the Swish employee-inventors maintained the pledge of confidentiality they had agreed to in their employment contracts.

Statutory Bar Exercises

???



5. During his September 15, 1998 retirement luncheon in Campos, Brazil, the senior engineer of a local sporting goods maker offers some advice on ways to improve the production of tennis racquets. The steps he proposes are quite similar to those ultimately suggested by Bjorn. The remarks are in Portuguese and go unrecorded.

6. Mr. Forehand is the President, chief executive officer, and sole shareholder of Unstrung Incorporated. Forehand is presented with the "Sports Manufacturing Person of the Year Award" at an elaborate industry-sponsored dinner on August 27, 2001. In a fit of largess following the acknowledgment by his peers, Forehand fully describes the Bjorn process during his acceptance speech. He then declares that "I believe this invention will transform the world of tennis and feel that all of us should participate in the dramatic possibility. I hereby dedicate our new invention to the public." The next morning, Forehand has second thoughts and orders the filing of a patent application as above.

7. Unstrung Incorporated's patent attorney contacts two foreign associates and asks them to file patent applications claiming the Bjorn process in Sweden and Germany, respectively. The Swedish application is filed on July 15, 2001 and issues on October 13, 2002. The German application is filed on August 17, 2001 and issues as a granted patent on January 15, 2003.

§102(a)

102(a) – "the invention was **known or used by others** in this country, or patented or described in a printed publication in this or a foreign country, before the invention thereof by the applicant for patent"

| | | |
|---|----------------------------------|--|
|  | public knowledge or | "Public" is an implied requirement, relates to that segment of the public most interested in the technology, public if no deliberate attempts to keep it secret. |
| | used by others | One use is sufficient, even if private, remote or widely scattered, public if no deliberate attempts to keep it secret. |
|  | patented or | • • • |
| | printed publication | • • • |

Woodcock v. Parker (MA Circuit Ct, 1819) (Story)

- If D has title to the patent from the “first and original” inventor, then P does not have an infringement cause of action
 - Jury instructions by Justice Story
- Notes
 - First & original inventor
 - Potentially novelty-destroying technology is measured from the date of invention, not the filing date
 - Disclosure of invention date
 - The PTO does not request this on an application, but rather makes ad-hoc requests using “Rule 131 affidavits”

Gillman v. Stern (2d 1940) (Hand)

- Gillman is asserting patent for “puffing machine”
 - It blows thread into fabric for an embossed design
- Patent dates
 - File date (f/d): 1/21/1931
 - Issued: 7/25/1933
- Two instances of prior use by Haas alleged
 - First alleged use was an “unsatisfactory temporary device” - an abandoned experiment
 - Dates of use unknown

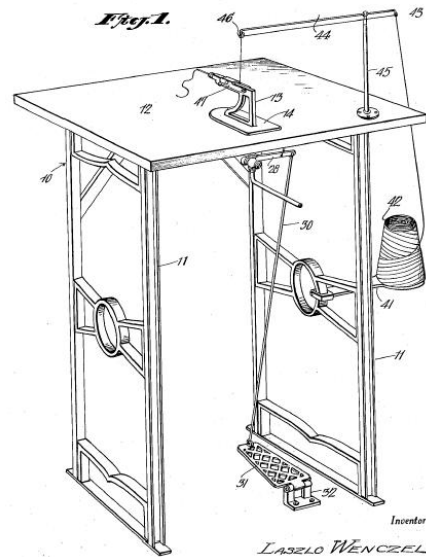

Gillman v. Stern (2d 1940) (Hand)



- **Second alleged use**
 - Issues existed as to whether this second device anticipated the patent, although it was “prior” because used in 1929
 - However, the dispute about anticipation (or even obviousness) for the second device did not matter because it was never in public use
 - It was always kept as strictly secret as possible
 - Many deliberate efforts to keep it secret
 - A secret inventor is not a “first inventor”
- **Informing use versus secret use?**
 - It is an anomaly that by secreting a machine away one may keep it from anticipating, even though its public use would really have told nobody anything about it
- **Result – an implied “public-ness” requirement in 102(a)**
 - “Public” means those skilled in the art
 - It does not require actual knowledge or use by the public, just that the prior invention was publicly accessible – in the open and used in the ordinary course of activities of the employer

Framework for §102(a) “known or used”

- Use three categories to sort the effect of the use of the invention:
 - whether it informs the public or others of the invention
 - whether it does not so inform, or
 - whether the use was explicitly the subject of efforts to keep it secret
- The table below is for the following question:
 - *Is it a “known or used” under §102(a)?*

| Actor | Informing Use | Non-informing Use | Secret Use |
|------------------|----------------------------------|--------------------------------|-------------------------------|
| Third Party (TP) | Yes <u>Woodcock v. Parker</u> | Yes <u>Gillman v. Stern</u> | No <u>Gillman v. Stern</u> |

“Swearing behind” or “antedating a reference”

- With a §102 or §103 rejection, applicant can overcome §102(a) & §102(e) PA unless
 - (i) the rejection is based on a US Patent or application claiming the same invention, in which case there may be an interference under §102(g); or (ii) the rejection is a statutory bar, §102(b)(d), in which case “swearing behind” does not work
- The declaration must set forth facts that the applicant had (i) actually reduced to practice (ARtoP) or (ii) conception (C) and diligence (D); starting before the date of the reference – so that now the reference is no longer “prior”

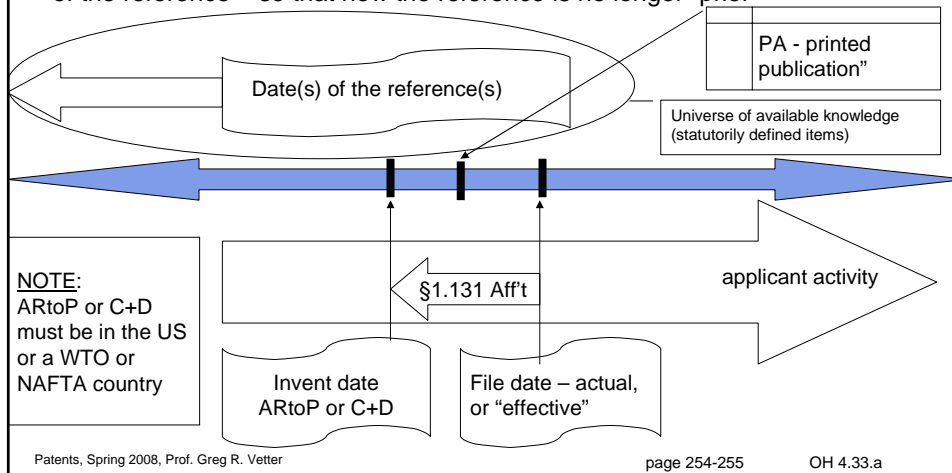

Antedating reference – earlier C+D+ARtoP/CRtoP

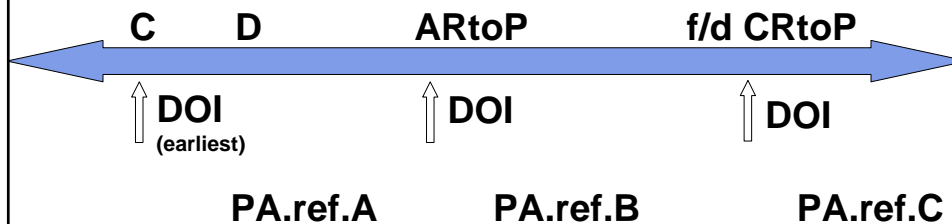

- Prior art references A, B & C are patents or printed publications anywhere in the world (but < 1 year before the f/d) or public knowledge or used by others in the US
- Which of A, B or C are legally sufficient to show lack of novelty?
 - Answer: None
 - Why?

| §102(g) | | |
|---|---|---|
| 102 | Statutory Language | Notes |
| | A person shall be entitled to a patent unless . . . [t]he invention was described in - | |
| (g) | | Serves two principle purposes: - resolving "priority," fountainhead of interference law [(g)(1)] - expressly stating the general rule of priority [(g)(2)] |
| (g)(1) | during the <u>course of an interference</u> conducted under section 135 [PTO] or section 291 [court], <u>another inventor</u> involved therein <u>establishes, to the extent permitted in section 104</u> , that <u>before such person's [the applicant's] invention</u> thereof the <u>invention was made by such other inventor</u> and <u>not abandoned, suppressed, or concealed</u> , or | Underlined items show elements of this category of prior art, which is the basis for "interference" proceedings. - "limits" of §104 means by relying on acts of invention wherever and whenever permitted by §104 - Occurs for rejection based on a US Patent or application claiming the same invention |
| (g)(2) | before such person's invention thereof <u>[i.e., before the applicant's DOJ]</u> , the <u>[claimed] invention</u> was <u>made in this country</u> by <u>another</u> inventor who had <u>not abandoned, suppressed, or concealed</u> it. | Underlined items show elements of this category of prior art (D identifies a TP who allegedly invented first). - "making" the invention may be in secret, but if it is thereafter A/S/or/C, then it loses its status as PA (i.e., as soon as it is "made" it cannot be A/S/or/C). - §104 does not apply to "in this country" [§104 allows an applicant to show conception and diligence outside the US in NAFTA or WTO countries] |
| (g) | In determining priority of invention under this subsection, there shall be considered not only the respective dates of <u>conception</u> and <u>reduction to practice</u> of the invention, but also the <u>reasonable diligence</u> of one who was first to conceive and last to reduce to practice, from a <u>time prior to conception by the other</u> . | - The sentence defines a narrow condition where even if an inventor was not the first to "make" he or she may win a priority "race" |
| <p>Patents, Spring 2008, Prof. Greg R. Vetter page 255-260 OH 4.34.a</p> | | |

| §102(g) | | |
|---|---|--|
| 102 | Statutory Language | Notes |
| (g)(1) | during the <u>course of an interference</u> conducted under section 135 [PTO] or section 291 [court], <u>another inventor</u> involved therein <u>establishes, to the extent permitted in section 104</u> , that <u>before such person's [the applicant's] invention</u> thereof the <u>invention was made by such other inventor</u> and <u>not abandoned, suppressed, or concealed</u> , or | Underlined items show elements of this category of prior art, which is the basis for "interference" proceedings. - "limits" of §104 means by relying on acts of invention wherever and whenever permitted by §104 - Occurs for rejection based on a US Patent or application claiming the same invention |
| <p>Patents, Spring 2008, Prof. Greg R. Vetter page 255-260 OH 4.34.b</p> | | |

| §102(g) | | |
|---|---|---|
| 102 | | Notes |
| (g)(2) | before such person's invention thereof <u><i>[i.e., before the applicant's DOI], the [claimed] invention</i></u> was <u><i>made</i></u> in <u><i>this country</i></u> by <u><i>another</i></u> inventor who had <u><i>not abandoned, suppressed, or concealed</i></u> it. | Underlined items show elements of this category of prior art (D identifies a TP who allegedly invented first). - "making" the invention may be in secret, but if it is thereafter A/S/or/C, then it loses its status as PA (i.e., as soon as it is "made" it cannot be A/S/or/C). - §104 does not apply to "in this country" [§104 allows an applicant to show conception and diligence outside the US in NAFTA or WTO countries] |
| <small>Patents, Spring 2008, Prof. Greg R. Vetter page 255-260 OH 4.34.c</small> | | |

| §102(g) | | |
|---|--|---|
| 102 | | Notes |
| (g) | In determining priority of invention under this subsection, there shall be considered not only the respective dates of <u><i>conception</i></u> and <u><i>reduction to practice</i></u> of the invention, but also the <u><i>reasonable diligence</i></u> of one who was first to conceive and last to reduce to practice, from a <u><i>time prior to conception by the other.</i></u> | - The sentence defines a narrow condition where even if an inventor was not the first to "make" he or she may win a priority "race" |
| <small>Patents, Spring 2008, Prof. Greg R. Vetter page 255-260 OH 4.34.d</small> | | |

Conception

- Five-element test that must be met for the ultimately claimed invention – mapped to the two-element test used by the court in Oka

- Formation
- in the Inventor's Mind
- of a Definite and Permanent Idea
 - In sufficient detail
- of the Complete and Operative Invention
- as it is thereafter applied in Practice

"the directing conception"

means for carrying out

Oka v. Youssefyeh (Fed. Cir. 1988) (Markey)

- Interference
 - Count is to compound w/ "angiotensin converting enzyme inhibition activity"
 - The indanyl glycine "version" of the count compound is typically
 - a 2-indanyl group, or
 - 5-indanyl group
- O relied on Japan f/d of 10/31/80
- Y seeks to prove a Date of Invention (DOI) before O's date
 - PTO awarded priority to Junior Party Y; over O
 - O relied on its 1980 Japan f/d, 10/31/1980, under §119, because at this time O could not prove an earlier DOI by showing acts of C + DD in a foreign country

Oka v. Youssefyeh (Fed. Cir. 1988) (Markey)

- Y offers several dates
 - 2/27/80 – documented idea of the selected compound via formula disclosing a broad genus
 - 10/10/80 – method of making a compound outside the count
 - Last week of Oct. 1980 – species of the selected compound (5-indanyl group)
 - 1/9/81 - ARtoP
- Conception of a species w/in a genus may constitute conception of the genus

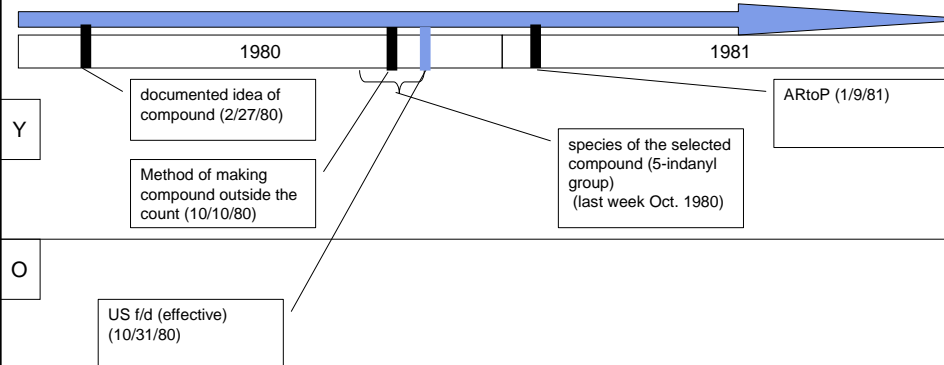

Oka v. Youssefyeh (Fed. Cir. 1988) (Markey)

- PTO cumulative findings for awarding Y 10/10/80 date
 - (i) no conception as of 2/27/1980 because POSITA could not make 2-indanyl version of the compound;
 - (ii) Y in possession of method of making a compound outside the scope of the count on 10/10/1980;
 - (iii) during last week of Oct. 1980, Y directed assistant S to make 5-indanyl class w/in the scope of the count;
 - (iv) S successfully did so in Dec. 1980;
 - (v) Y had ARtoP on 1/9/1981
 - So, PTO said “an operative procedure” was realized for preparing the 5-idanyl on 10/10/1980.

Oka v. Youssefyeh (Fed. Cir. 1988) (Markey)

| Macro-element of Conception Test | 2-indanyl version of count compound | 5-indanyl version of count compound |
|---|--|---|
| “the directing conception” | < 10/31: Satisfied 10/31: Satisfied | < 10/31: Lacking 10/31: Satisfied |
| means for carrying out | < 10/31: Lacking 10/31: Lacking | < 10/31: Satisfied?? 10/31: Satisfied |
| <ul style="list-style-type: none"> • If Y satisfies both parts of the conception test as of 10/31/80, why doesn't Y win? <ul style="list-style-type: none"> • When a date is established by testimony to fall within a range, the end of the range is credited as the date • Effect on the outcome? • Other points <ul style="list-style-type: none"> • Inventor must present proof showing possession or knowledge of each feature of the count and communicated to a corroborating witness in sufficient detail to enable a POSITA • One needs proof (documentation) that one thought about it <ul style="list-style-type: none"> • Why have this stringent corroboration requirement? | | |
| <small>Patents, Spring 2008, Prof. Greg R. Vetter</small> <small>page 260-264</small> <small>OH 4.35.e</small> | | |

Conception HYPO

- Conception = Inventorship
- HYPO
 - Inventor “A” invents a compound to cure indigestion
 - A has a technician “T” test it
 - T discovers that the compound does not work
 - T makes a change to the compound, never tells A
 - T retests, and discovers that the compound now works to cure indigestion
 - Neither A nor T are the sole inventors
 - Neither alone had a “complete and operative” idea of the invention

Actual Reduction to Practice (ARtoP)

● Elements

- Physically building or performing
- Testing sufficient to demonstrate
 - whether the invention works (is suitable) for its intended purpose
 - Occurs when the last test needed to show operability is completed & the inventor understood the test to be successful
 - Sufficiency of testing is evaluated on a continuum
 - Issue of Scott v. Finney
- ARtoP must be corroborated
 - Inventor's testimony alone is insufficient

Scott v. Finney (Fed. Cir. 1994) (Rader)

- Subject of the interference
 - "count" to an implantable penile prosthesis w/ at least one member, member having a forward and rearward section, valve separating the two sections
 - a pump external to the prosthesis member (but internal to the patient) moves fluid from the rearward section to the forward section, past the valve, causing the member to become elongated
 - Count is to one member, but invention envisions one member implanted on each side
- Procedural setup of interference
 - F has the earlier f/d, so he is "senior;" S claims he can show ARtoP before F's f/d

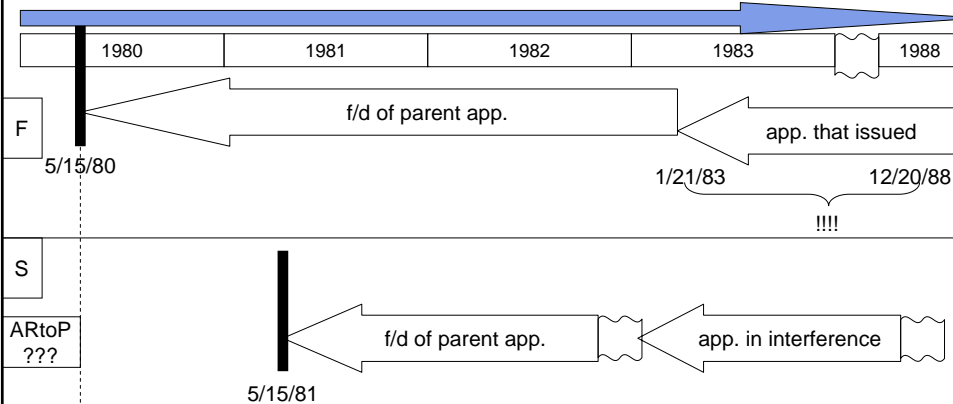

Scott v. Finney (Fed. Cir. 1994) (Rader)

- PTO Board awarded priority to Dr. Finney, senior party, holding that Scott, Junior party (& Burton) did not show an ARtoP before Finney's DOI (f/d of the parent application)
- Federal Circuit reversed, finding the testing sufficient

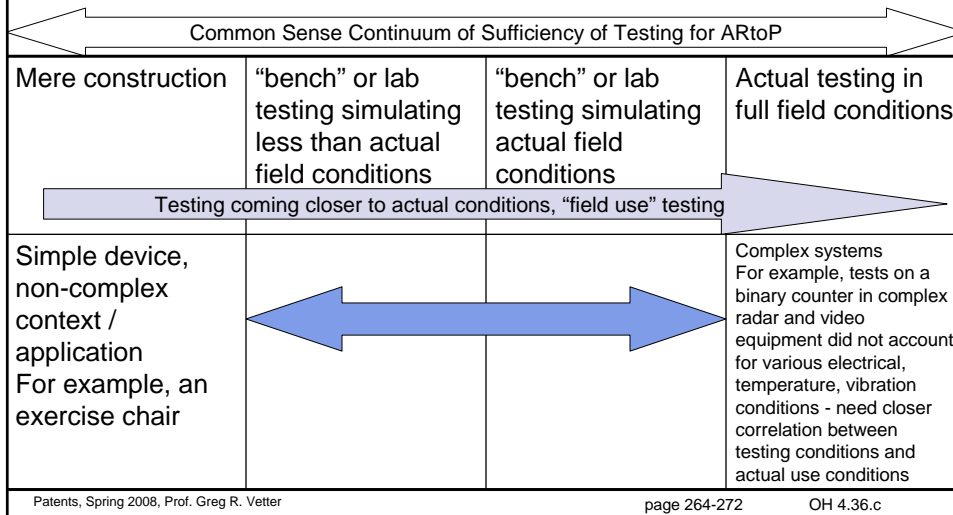

Scott v. Finney (Fed. Cir. 1994) (Rader)

- What is quality and quantity of testing required to show that invention works for its intended purpose?
 - Some devices are so simple that their purpose and efficacy is so obvious that complete construction (but not use) is sufficient to demonstrate workability
 - Factual analysis
 - Does not require that when tested that the invention be in a commercially satisfactory stage of development
 - "Testing need not show utility beyond a possibility of failure, but only utility beyond a probability of failure."

Scott v. Finney (Fed. Cir. 1994) (Rader)

- Two possible problems with Scott's test:
 - (i) only implanted one member
 - But, the count only covered one member, so not an issue
 - (ii) did not leave the member in and have the patient use it during intercourse
- Court's analysis
 - This device is simple enough in principle that the law should not require testing in actual service
 - The law should only require full and actual testing where a POSITA would require such testing
 - The test shown on the videotape was sufficient
 - ARtoP of these type of devices does not always require human testing
 - The inventor does not have to meet FDA standards of device safety or efficacy testing

ARtoP - HYPO

- When does ARtoP occur in the following scenario:
 - An inventor installs a video camera in a lab that continuously tapes the experiment over the weekend
 - No one is in the lab all weekend, but the tape clearly shows at 8 pm Sunday evening that the test worked
 - The inventor reviews the tape Monday morning at 9 am, and at that time appreciates that the results of the experiment are successful
- When is ARtoP?
 - Sunday at 8 pm?
 - Monday at 9 am?

Gould v. Schawlow (CCPA 1966)

- Interference proceeding over laser technology
- S is Senior Party
- G is trying to prove earlier DOI
 - G was first to conceive (C)
 - but last to RtoP (via filing) [Diligence only matters in this situation]
 - After C, G was (in his words) trying to
 - Determine the optimal “working medium” of the laser
 - Find a locale/job where the development could be funded & continue
- Board decision
 - It awarded priority to Shawlow
 - Determined that it could not make the necessary inferences from G’s offered evidence to account for the lapses in the critical diligence period

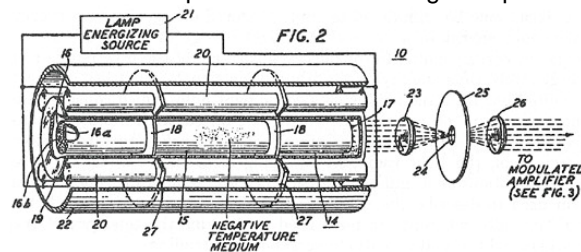

Patents, Spring 2008, Prof. Greg R. Vetter

page 272-279

OH 4.40.a

Gould v. Schawlow (CCPA 1966)

- G says that from Nov. 1957 to Dec. 1958, he worked on the laser every week, 1000 hours total
- G offers: (i) his testimony; (ii) his wife’s testimony; (iii) some “notebooks”; and (iv) testimony of his patent attorney

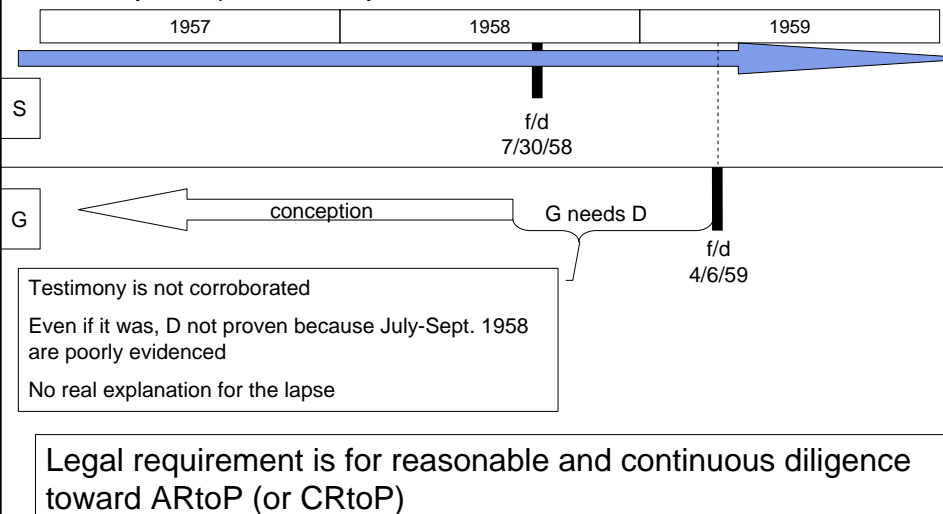

Patents, Spring 2008, Prof. Greg R. Vetter

page 272-279

OH 4.40.b

Corroboration

- Inventor may make use of C, D or ARtoP – only if corroborated
- Corroboration of oral evidence of prior invention is the general rule in patent disputes
 - 8 factors in assessing corroboration – “rule of reason” analysis
 - (1) the relationship between the corroborating witness and the alleged prior user,
 - (2) the time period between the event and trial,
 - (3) the interest of the corroborating witness in the subject matter in suit,
 - (4) contradiction or impeachment of the witness' testimony,
 - (5) the extent and details of the corroborating testimony,
 - (6) the witness' familiarity with the subject matter of the patented invention and the prior use,
 - (7) probability that a prior use could occur considering the state of the art at the time,
 - (8) impact of the invention on the industry, and the commercial value of its practice.

Corroboration

- Two example fact patterns where evidence was not sufficient to overcome the CCE standard required to invalidate a patent
 - Barbed Wire Patent Case – on patent issued in 1874, 24 people testified that they saw/experienced the barbed wire at a county fair in 1858
 - Lower court said that it is unlikely all 24 were lying, invalidated the patent
 - US Supreme Court reversed
 - Witnesses whose memories are prodded by the eagerness of interested parties to elicit testimony favorable to themselves are not usually to be depended upon for accurate information
 - Woodland – district court invalidated a patent on method to protect foliage from freezing on the basis of testimony by 4 individuals that the defendant used the method for 10 years 30 years prior to the plaintiff's invention
 - Federal Circuit reversed, rejecting the district court's logic that it was unlikely that all 4 witnesses for defendant were perjurers
 - Uncorroborated oral testimony, of interested persons of events long past, does not meet CCE standard
- Shop-Book Rule – FRE 803(6)
 - Does not apply to reports of scientific work in interference proceedings

Apotex USA v. Merck (Fed. Cir. 2001) (Lourie)

- Apotex patent claims are to process of making a stable compound for use in treatment of high blood pressure
- District court found the two Apotex patents invalid under 102(g)
 - Merck invented the process before Apotex & did not A/S/or/C.
- It is conceded that Merck invented the process well before Apotex's Dr. Sherman conceived the invention
 - Also conceded that Merck did not abandon it
 - So, the sole issue is whether Merck "suppressed" or "concealed" (S/or/C) it
- Merck manufactures the compound (since 1983), and has patent claims to the compound, but none on the process of manufacturing it
- In 1988, Merck publicly disclosed ingredients of its compound in a French pharmacological dictionary
- Merck Canada sued Apotex Canada in 1991
 - The case exhibits included a videotape of Merck's manufacturing process
 - After an Apotex employee saw the video on 3/28/94, detailing Merck's manufacturing process, the Apotex employee allegedly conceived of the Apotex manufacturing process invention a few days later

Apotex USA v. Merck (Fed. Cir. 2001) (Lourie)

- Federal Circuit analysis
 - Language of 102(g) requires the invention be "made" in this country
 - but A/S/or/C could be anywhere
 - Congress could have limited A/S/or/C if it wanted
 - The "in this country" modifier was removed from an earlier draft provision
- Burden of proof / production issue
 - We therefore interpret §102(g) as requiring that once a challenger of a patent has proven by clear and convincing evidence that "the invention was made in this country by another inventor," §102(g), the burden of production shifts to the patentee to produce evidence sufficient to create a genuine issue of material fact as to whether the prior inventor has suppressed or concealed the invention. However, in accordance with the statutory presumption in §282, the ultimate burden of persuasion remains with the party challenging the validity of the patent. Once the patentee has satisfied its burden of production, the party alleging invalidity under §102(g) must rebut any alleged suppression or concealment with clear and convincing evidence to the contrary.

Apotex USA v. Merck (Fed. Cir. 2001) (Lourie)

- Two types of S/or/C
 - (i) active;
 - (ii) legal inference of S/or/C based on unreasonable delay in filing
- This case involved issues relating to the second type of S/or/C
 - The first inventor takes the risk of someone else patenting the invention if she does not properly make the public aware that it is in the public domain
 - So, for the legal inference form of S/or/C, a party is deemed S/or/C “if, within a reasonable time after completion, no steps are taken to make the invention publicly known”

Apotex USA v. Merck (Fed. Cir. 2001) (Lourie)

- Apotex has created a GIMF on the proposition that Merck S/or/C
 - It has satisfied its burden of production
 - 102(g) has no requirement that a party must apply for a patent
 - However, not patenting is a relevant factor
 - Here, Apotex alleged other factors, such as that Merck failed to make the process publicly known
 - 5 years from start of manufacturing (1983) to listing ingredients in Canada drug dictionary (1988)
 - Apotex tries to counter by arguing that Merck's 1992-94 activity was not full disclosure
 - But the court says that a POSITA could look at Merck's pill & know the process by which it was made in conjunction w/ the published ingredients list
- Under 102(g)(2), Merck showed by CCE that the invention “was made in this country by another inventor”
- But, Merck has by CCE, rebutted the inference (via inactivity) of S/or/C
 - Merck **resumed activity** before Apotex entered the field
 - Distributed product monograph in 1992-94
 - Presented litigation video on March 28, 1994
 - Apotex's Dr. Sherman conceived (allegedly) in April 1994

§102(g) Exercises

- Blackstone conceives of an improved can opener on January 1, 1990; reduces the invention to practice on June 1, 1990; and files a patent application claiming the can opener on February 1, 1991. Maitland conceives of the same can opener on March 1, 1990; reduces it to practice on August 1, 1990; and files a patent application directed towards the can opener on December 1, 1990. Which party is entitled to priority of invention?

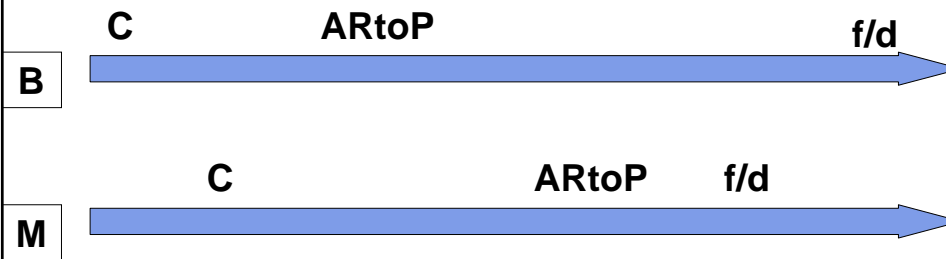

- ANSWER:
 - As the first to RtoP, B obtains priority of invention over M
 - This is the most common resolution of 102(g) situations

§102(g) Exercises

- On July 4, 1995, Hector conceives of a novel clock recovery circuit for use in fiber optic receivers. He sets the project aside until November 25, 1995, and after several weeks of continuous experimenting ultimately reduces the invention to practice on December 25, 1995. Hector then files a patent application with three independent claims directed towards the circuit on January 1, 1996. Nestor conceives of the same circuit on August 1, 1995; reduces it to practice on September 1, 1995; and files a patent application claiming the circuit on October 1, 1995. Which party is entitled to priority of invention?

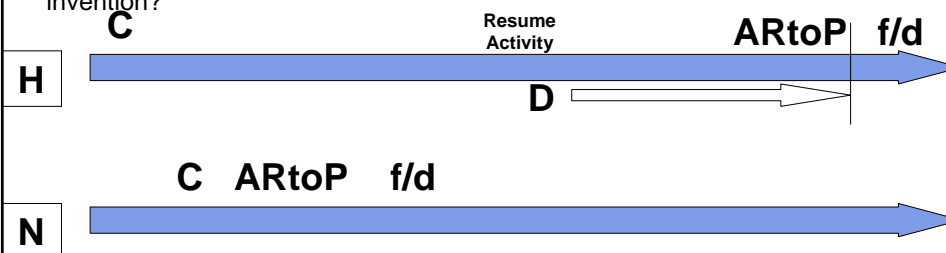

- ANSWER:
 - Nestor obtains priority of invention as the first to RtoP
 - Hector does not fulfill the "exception" language of 102(g) because he was not diligent soon enough

§102(g) Exercises

- Hotspur conceives of a new optical recording media on March 21, 1993. He never builds a working model of the media, but does diligently file a patent application claiming the recording media on December 1, 1993. Margaret conceives of the identical recording media on April 1, 1993, diligently works on the invention until finally reducing it to practice on May 1, 1993, and files a patent application claiming the recording media on August 15, 1993. Which party is entitled to priority of invention?

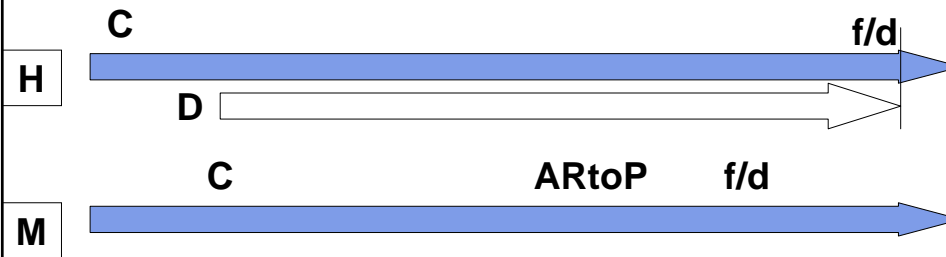

- ANSWER:
 - Hotspur obtains priority because he fulfills the “exception” condition of 102(g)
 - Hotspur’s filing date is a constructive reduction to practice
 - Whether Margaret was diligent or not is not relevant

Alexander Milburn v. Bournonville (US 1926) (Holmes)

- Whitford welding patent is being asserted
- D cites Clifford reference as invalidating
- Holmes logic
 - If Whitford had filed after C issued, it is clear that C, as a printed pub, anticipates
 - So, “the delays of the patent office ought not to cut down the effect of what has been done.”
 - C has done all he could to make his invention public – he took steps to make it public – and it will be public as soon as the patent office has done its work
- Later codified in 102(e)(2)
- PA = KNOWABLE state of the art at the time of invention
 - This result is an exception to the inclination against “secret” PA

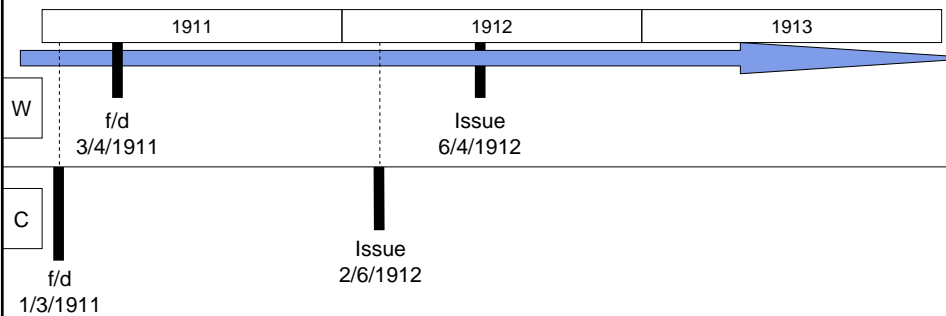

| §102(e) | | |
|--|---|---|
| 102 | Statutory Language A person shall be entitled to a patent unless . . . [t]he invention was described in - | Notes |
| (e) | | Disclosure (unclaimed subject matter) in a reference US patent does not fall under §102(g), but rather falls under §102(e). [In other words, 102(e) is for a patent that does not claim the invention] |
| (e)(1) | an application for patent, published under section 122(b) , by another filed in the United States before the invention by the applicant for patent | Effective date of an application, as a reference , if the application is published under §122(b), is its effective US f/d, i.e., domestic priority applies [§119(e), §120] - "another" means a different inventive entity - §122(b) requires publication of applications (even if not yet issued) 18 months after earliest filing date. NOTE: under (e)(1) it does not matter if the published application never issues |
| (e)(2) | a patent granted on an application for patent by another filed in the United States before the invention by the applicant for patent | Effective date of a US patent as a reference is its US f/d - "another" means a different inventive entity - Foreign priority f/d does not apply [§119(a)] - Domestic priority f/d does apply [§119(e), §120] |
| (e) | except that an international application filed under the treaty defined in section 351(a) shall have the effects for the purposes of this subsection of an application filed in the United States only if the international application designated the United States and was published under Article 21(2) of such treaty in the English language | An application published by WIPO under the Patent Cooperation Treaty (PCT), if published in English and designating the US, is a reference as of its PCT filing (not publication) date (which is also its effective US f/d). This also means that a US patent issuing from an international application meeting these conditions will have a 102(e) prior art date corresponding to the international filing date |
| Patents, Spring 2008, Prof. Greg R. Vetter | | OH 4.45 |

| <u>Agawam Woolen v. Jordan (US 1868)</u> | |
|---|------------------------|
| <ul style="list-style-type: none"> ● Patented machine for manufacturing wool & other fibrous materials ● Patentee's assignee brought infringement action against Agawam ● The lower court took evidence that the patentee received considerable assistance from Ed Winslow <ul style="list-style-type: none"> ● Winslow was a blacksmith employed by the patentee ● Issue is whether this assistance in creating the improved machine rose to a level such that the patentee derived from Winslow ● Court rejects that the patentee derived from Winslow. ● Court notes that "suggestions from another . . . must have embraced the plan of the improvement [and be enabling]" <ul style="list-style-type: none"> ● Original inventorship is not negated merely by reason of having received a suggestion or material from another ● The communication must have "enabled an ordinary mechanic . . . to construct and put the improvement in successful operation" | |
| Patents, Spring 2008, Prof. Greg R. Vetter | page 300-305 OH 4.46.a |

Agawam Woolen v. Jordan (US 1868)

- Statutory codification is §102(f)
 - One is not entitled to a patent if one claims an invention he or she did not conceive
 - Derivation is claiming an invention I did not conceive
 - Inventive entity is important
 - For example, a father cannot claim an invention that is really from a joint invention of the father and his daughter
 - §102(f) applies to factual situations where §102(a) does not apply
 - There is no “in this country” limitation
- Other formulations of the derivation standard
 - Taking the gist or essence of the invention
 - Can there can still be derivation even if some limitation(s) were not derived? How much of the “invention” has to be communicated? The claimed invention, i.e., an anticipating communication? Or, something less?
 - Taking so much of the claimed invention as would have made the claimed invention obvious to a POSITA
 - OR
 - The “enablement” standard of Agawam - “enabled an ordinary mechanic . . . to construct and put the improvement in successful operation”

Novelty Exercises

???

While working in her United States laboratory, Andrea conceives of the idea of using a certain compound as a semiconductor dopant on January 10, 2001. She writes the idea down in her notebook under the heading "Dopant X Project," but immediately puts it aside in favor of completing some other projects of a personal and professional nature. Eventually, she turns again to "Dopant X," and after some intermittent efforts she fabricates a working semiconductor chip on August 14, 2001. She immediately notifies her patent attorney of the invention, and an application is filed on October 1, 2001. During this entire process, she maintains the invention in secrecy.

Based upon the different additional facts provided below, will Andrea be awarded priority of invention? Unless otherwise noted, assume that all activity occurred within the United States.

1. Benkei, an electrical engineer based in Japan, had described the use of Dopant X in a Japanese electronics journal published on November 3, 2000 [NOTE – book gives this date as 2001, the posted answer is for a date in the year 2000].

2. Chelsea conceived of Dopant X on June 15, 2001, and by working continuously on the project was able to produce the chip on September 1, 2001.

Novelty Exercises

???

3. Diane developed the idea of using Dopant X on September 3, 2000. She did nothing more on the project until the start of the new year, but then worked on a full-time, daily basis beginning January 3, ~~1999~~ 2001. She was at last able to construct a working chip on November 20, 2001.

4. Edward conceived of the invention on January 15, 2001, and continued work on the project for the next two months. After several false starts, he halts work on the project entirely on March 21, 2001. After spending some spare moments reflecting on his earlier work in the early summer months, he then renews his efforts on the project in late July. He successfully builds the semiconductor on August 7, 2001.

5. Felicia conceives of a new transistor on June 20, 2000 and immediately informs her patent agent. A patent application claiming the transistor is filed on December 1, 2000. Along with several other doping agents described as useful in implementing the transistor through semiconductor materials, the application's specification suggests the use of Dopant X. Felicia then constructs the transistor using a known dopant on June 4, 2002. Her patent is granted on April 23, 2003.