

## Licensing & Tech. Transfer

- Module 7
- Implied Licenses

## Wang Laboratories, Inc. v. Mitsubishi Electronics America, Inc. (Fed. Cir. 1997)

- What did Wang patent?
- How did they promote it?
- What was the general effect of the promotion?
- What did Mitsubishi do?
  - What type of help did they have?
- Interaction of patents with industry standards
- Dist. Ct. result for the two patents
- Fed. Cir. analysis
  - Basis for appeal
  - Types of implied license



## Foad Consulting v. Musil Govan Azzalino (9th Cir. 2001)



- Developers and designers
  - GenCom -> Claire -> Hawkeye
  - Foad; then MGA's predecessor as the copyist
  - Shopping center project; Foad design plans approved by city of Arroyo Grande in California
- Dist. Ct. S/J loss by Foad
- No transfer/assignment of exclusive rights
- Federal law: an implied nonexclusive license can be created because copyright law doesn't regulate nonexclusive licenses
  - State law: was it?
- Ways to show implied nonexclusive license: testimony, course of conduct, custom and practice
  - Foad contract "for" the shopping center
  - Drawing legend: other projects, or restrict this one?
  - Indemnification clause
  - Ownership clause
- Categorization?

Licensing, Spring 2014, Prof. Greg R. Vetter

7-3

## IAE v. Shaver (7th 1996)

- J/V of IAE and BEMI hired Shaver as architect
  - Shaver delivered first of 4 drawings sets keyed to design phases: schematic design drawings
- New architect
  - Shaver letter to airport director
  - Shaver approach to J/V
- 3 prongs of Effects Associates
  - Request
  - Delivery
  - Intend recipient to copy and distribute
- Scope of implied license?
- Post-script
  - AIA Doc. B151 1997

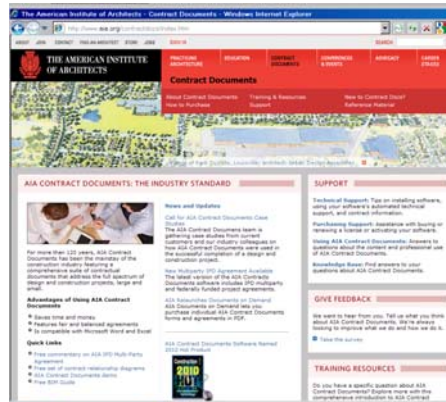

Licensing, Spring 2014, Prof. Greg R. Vetter

7-4

## Hilgraeve v. Symantec (Fed. Cir. 2001)

- Symantec patent litigation defense
  - License from a series of transactions
    - 6/30/1993 – Tech Xfer K (transferring what?)
    - 6/30/1993 – SDCS K
    - 7/1995 – Symantec acquired Delrina
    - 3/30/1996 – Delrina L'OR to Symantec
    - 3/2/1999 – Delrina Xfer to Symantec
- Transfer of “know how and technical expertise”
- Provision in sec. 2.2 of Tech Xfer K
  - How does Symantec use it to try to help itself?
  - How does the court use it to diminish Symantec's argument?

## AMP Inc. v. United States (U.S. Ct. Cl. 1968)

- “Subject Invention” clauses in development agreement
  - What was licensed?
- Byrem patent developed under the agreement
- Vinson patent?
  - Relation to Byrem patent?
  - Relation to development agreement?
- Precedent for “legal estoppel”
  - Not “estoppel in pais” (misrep.)
  - United Printing Machinery (assign)
  - Curran v. Burdsall (assign)
  - Scovill v. Radio (two assignments)
  - Stevens v. Steel & Tubes (lic.)

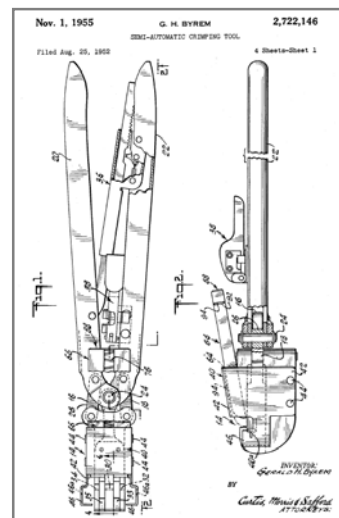

Note: this was not a full case in the book

## Jacobs v. Nintendo (Fed. Cir. 2004)

- Jacobs
  - U.S. Pat. No. 5,059,958, entitled "Manually Held Tilt Sensitive Non-Joystick Control Box."
- Settlement agreement after Jacob's suit against Analog Devices
  - granted Analog a license to undertake acts otherwise infringing, and: "the license granted hereunder includes the right to make, use, sell, import and export components, including micromachined accelerometers, for use in tilt-sensitive control boxes."

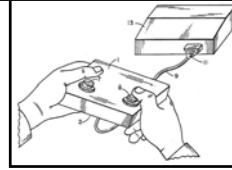

We agree with the district court that the clause granting Analog the right to sell its accelerometers for use in tilt-sensitive control boxes barred Jacobs from interfering with that right by prohibiting Analog's customers from using the accelerometers for that authorized purpose by making, using, and selling control boxes incorporating Analog's devices. That interpretation is in accordance with the basic contract law principle that a party may not assign a right, receive consideration for it, and then take steps that would render the right commercially worthless.

- peace & prosperity?

## Met-Coil v. Korner's (Fed. Cir. 1986)

- What does Met-Coil's subsidiaries make and sell?
- What does Korner's sell?
- Who is the (alleged) direct infringer?

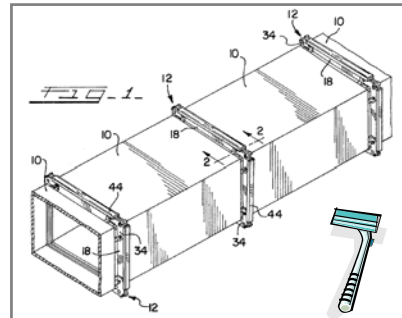

**[(2)] A patent owner's unrestricted sales of a machine useful only in performing the claimed process and producing the claimed product "plainly indicate that the grant of a license should be inferred."**

## Anton/Bauer, Inc. v. PAG, Ltd. (Fed. Cir. 2003)

- Accused device is PAG L75 Battery Pack
- Dist. Ct. grants A/B prelim. inj.
- What is claimed?
- What does A/B supply to the market? How sold?
- Fed. Cir. analysis
  - Univis exhaustion
  - Met-Coil implied license

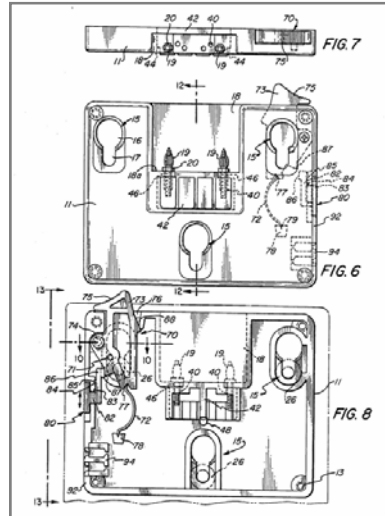

## Jazz Photo v. US (Fed. Cir. 2001)

- Import proceeding before the Int'l Trade Commission
  - Determination that Jazz and others infringed all or most of Fuji's 14 US patents
  - Order to stop importing "single-use" cameras called "lens-fitted film packages" (LFFP)
  - LFFPs refurbished in various overseas factories
- The 8-step refurbishment process at issue here is repair, not reconstruction

- Claim 1 paraphrase
  - Casing w/ opening for exposure
  - Unexposed rolled film
  - Film container on opposite side of film, having a winding spool, film from roll attached
  - Means for winding
  - Winding control means, externally operable, advancement for one frame, including a sprocket wheel driven by movement of the film
  - Frame counter driven by the sprocket wheel, means for disabling the winding control means

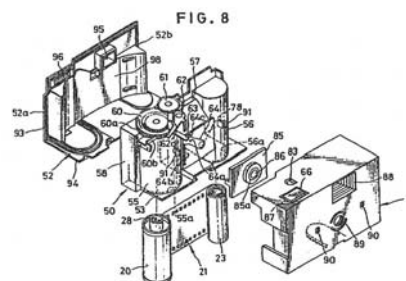

### Jazz Photo v. US (Fed. Cir. 2001)

- Law or Repair / Reconstruction
  - Personal property rights attach from the sale, only subject to patentee's right to "make"
    - But, must give owner the right to preserve the useful life of the original article
    - For example, replacing the blades in a machine when the machine lasts several years and the blades need replacing 60-90 days
  - Does the activity "in fact make a new article" after the original entity, viewed as a whole, has become spent
  - Mere repair
    - Disassembly and cleaning
    - "overhauling" gun mounts – even when done using an assembly line method
    - Rebuilding truck clutches – even when done in a large scale commercial operation
      - Repair parts purchased from the patentee
      - Patentee contemplated rebuilding
- Related and underlying – principle of exhaustion

### Jazz Photo v. US (Fed. Cir. 2001)

- Exhaustion
  - Arises from the unrestricted sale by the patentee or with authority of the patentee
  - "exhausts" the patentee's right to control further sale and use of that article by enforcing the patent under which it was first sold
  - The "exhaustion" "runs with the res"
  - No exhaustion of US patent rights by sales overseas
- Here, the reversal of the Commission's infringement determination applies only to articles that have been "exhausted"

### Jazz Photo v. US (Fed. Cir. 2001)

- Reconstruction
  - Infringing reconstruction must be a “second creation”
  - Patentee’s unilateral intent cannot govern the inquiry
    - Somewhat contrary to this approach is the Sandvik case
      - The drill bit at issue was not designed nor intended to be a replaceable part or to be “retipped”
      - It did not have a differing life expectancy from the shank
      - No sales of replacement tips, nor instructions on how to do so
  - Not necessarily any specific factors that are controlling
    - a license to use a patented combination includes the right to preserve its fitness for use
    - the remaining useful capacity of the article
    - the nature and role of the replaced parts in achieving that useful capacity

### Jazz Photo v. US (Fed. Cir. 2001)

- Common steps for refurbishment
  - (1) removing the cardboard cover,
  - (2) cutting open the plastic casing,
  - (3) inserting new film and a container to receive the film,
  - (4) replacing the winding wheel for certain cameras,
  - (5) replacing the battery for flash cameras,
  - (6) resetting the counter,
  - (7) resealing the outer case, and
  - (8) adding a new cardboard cover
- These are more like Aro and the other precedents
- For patented components that were simply reused, no issue at all of repair/reconstruction

**McCoy v. Mitsubishi Cutlery, Inc., (Fed. Cir. 1995)**

- What did McCoy and ATD do?
- What resulted, and how did this become alleged patent infringement by Mitsubishi?
- Dist. Ct. analysis
  - patent
  - trademark
  - Federal unfair competition
  - tortious interference
- Fed. Cir. analysis

